



P U M P

OPERATION, PERFORMANCE, SPECIFICATIONS and PARTS MANUAL

**3ANC300, 3ANC500, 3ANC750, 4ANC2500, 4ANC3000,
4ANC4000, 6ANC1000, 6ANC1500, 6ANC2000,
6ANC3000, 6ANC4000, ANC5000, 6ANC6000,
8ANC5000, and 8ANC6000**

Heavy Duty Solids Handling Pumps



- Thank you for purchasing this pump. Take the time to read the instructions carefully before using this product. We strongly recommend that you keep this instruction manual in a safe place for future reference.
- Please refer to our website and the Products Center for additional installation and operation instructions and replacement parts information.

MARKS AND MEANING:

⚠ DANGER

“Danger” indicates an imminent hazardous situation which, if not avoided, WILL result in death or serious injury.

⚠ WARNING

“Warning” indicates an imminent hazardous situation which, if not avoided, MAY result in death or serious injury.

⚠ CAUTION

“Caution” indicates a potentially hazardous situation which, if not avoided, MAY result in minor or moderate injury.



Solids Handling Pumps

Models: 3ANC300/500/750, 4ANC2500/3000/4000/5000/6000, 6ANC1000/1500/2000/3000/4000/5000/6000, 8ANC5000/6000 General Safety Information

Before installation, read the following instructions carefully. Failure to follow instruction and safety information could cause serious bodily injury, death and/or property damage. Each Ashland Pump is individually factory tested to ensure proper performance. Closely following these instructions will eliminate potential operating problems assuring years of trouble-free service.

Most accidents can be avoided by using common sense.

IMPORTANT - Ashland Pump is not responsible for losses, injury or death resulting from failure to observe these safety precautions, misuse, abuse or misapplication of pumps or equipment.

⚠ DANGER All returned products must be cleaned, sanitized, or decontaminated prior to shipment, to insure employees will not be exposed to health hazards in handling said materials. All applicable laws and regulations shall apply.



⚠ WARNING Bronze/brass fitted pumps may contain lead levels higher than considered safe for potable water systems. Government agencies have determined that leaded copper alloys should not be used in potable water applications.

⚠ WARNING Installation, wiring, and junction connections must be in accordance with the National Electric Code and all applicable state and local codes. Requirements may vary depending on usage and location.

⚠ WARNING Installation and servicing is to be conducted by qualified personnel only.

⚠ DANGER Rotating machinery, amputation or severe lacerations can result. Keep clear of suction and discharge openings. DO NOT insert fingers into pump with power connected.



⚠ WARNING Always wear eye protection when working on pumps. Do not wear loose clothing that may become entangled in moving parts.

⚠ DANGER Pumps build up heat and pressure during operation. Allow time for pumps to cool before handling or servicing.

⚠ DANGER Hazardous Voltage can shock, burn or cause death. This pump is not intended for use in swimming pools or water installations where human contact with pumped fluid is possible.



⚠ DANGER Risk of electrical shock. To reduce risk of electrical shock, always disconnect pump from source before handling. **Lock out power & tag.**



⚠ WARNING Do Not use these pumps in water over 145°F. Do not exceed manufactures recommended maximum performance, as this could cause the motor to overheat.

⚠ CAUTION Make sure lifting handles are securely fastened each time before lifting.

⚠ DANGER Do not lift, carry or hang pump by the electrical cables. Damage to the electrical cables can cause shock, burns or death. Never handle connected power cords with wet hands. Use appropriate lifting device.



⚠ WARNING Pumps often handle materials which could cause illness or disease. Wear adequate protective clothing when working on a used pump or piping. Never enter a basin after it has been used.

⚠ DANGER Failure to permanently ground the pump, motor and controls before connecting to power can cause shock, burns or death.



⚠ DANGER These pumps are NOT to be installed in locations classified as hazardous in accordance with the National Electric Code, ANSI/NFPA 70.



⚠ WARNING Do not introduce into any sewer, either directly, or through a kitchen waste disposal unit or toilet: Seafood Shells, Aquarium Gravel, Cat Litter, Plastic Objects, Sanitary Napkins or Tampons, Diapers, Rags, Disposable Wipes or Cloth, Medications, Flammable Material, Oil or Grease, Strong Chemicals, Gasoline.

- Operation against a closed discharge valve will cause premature bearing and seal failure on any pump.
- Any wiring of pumps should be performed by a qualified electrician.
- Cable should be protected at all times to avoid punctures, cuts, bruises, and abrasions-inspect frequently.
- Never handle connected power cords with wet hands.
- Never let cords or plugs lie in water outside the sump pit.
- These pumps are offered in a three phase and single phase wiring configuration. Voltages will vary according to the application and can be seen in the tables in this manual.



Solids Handling Pumps

Models: 3ANC300/500/750,
4ANC2500/3000/4000/5000/6000,
6ANC1000/1500/2000/3000/4000/5000/6000,
8ANC5000/6000 Specifications

IMPORTANT Prior to installation, record Model Number, MFG Date, Amps, Voltage, Phase and HP, from pump nameplate for future reference. Also record the voltage and current readings at startup:	1 Phase Models		Model Number: _____
	Amps:	Volts:	MFG Date: _____
	3 Phase Models		Phase: _____
	Amps L1-2:	Volts L1-2:	HP: _____
	Amps L2-3:	Volts L2-3:	SN: _____
Amps L3-1:	Volts L3-1:		

MODEL RUN	HP	HZ	VOLTS/PH	RPM	FULL LOAD AMPS	START CODE	NEMA TYPE	CORD SIZE	CORD O.D.	CORD RELAY	POTENTIAL CAPACITOR	START CAPACITOR
3ANC300M3	3	60	230/3	1750	9	K	SOOW	14AWG	.58	N/A	N/A	N/A
3ANC300M4	3	60	460/3	1750	4.5	K	SOOW	14AWG	.58	N/A	N/A	N/A
3ANC500M3	5	60	230/3	1750	16	K	SOOW	12AWG	.65	N/A	N/A	N/A
3ANC500M4	5	60	460/3	1750	8	K	SOOW	12AWG	.65	N/A	N/A	N/A
3ANC750M3	7.5	60	230/3	1750	21	K	SOOW	10AWG	.72	N/A	N/A	N/A
3ANC750M4	7.5	60	460/3	1750	10.5	K	SOOW	10AWG	.72	N/A	N/A	N/A
4ANC3000M3	30	60	230/3	1750	76	G	SOOW	6AWG	1.08	N/A	N/A	N/A
4ANC3000M4	30	60	460/3	1750	38	G	SOOW	6AWG	1.08	N/A	N/A	N/A
4ANC4000M4	40	60	460/3	1750	50	G	SOOW	6AWG	1.08	N/A	N/A	N/A
4ANC5000M4	50	60	460/3	1750	60	G	SOOW	6AWG	1.08	N/A	N/A	N/A
4ANC6000M4	60	60	460/3	1750	80	G	SOOW	6AWG	1.08	N/A	N/A	N/A
4ANC2500M3	25	60	230/3	1750	66	G	SOOW	6AWG	1.08	N/A	N/A	N/A
4ANC2500M4	25	60	460/3	1750	33	G	SOOW	6AWG	1.08	N/A	N/A	N/A
6ANC1000M3	10	60	230/3	1750	28	H	SOOW	8AWG	.960	N/A	N/A	N/A
6ANC1000M4	10	60	460/3	1750	14	H	SOOW	8AWG	.960	N/A	N/A	N/A
6ANC1500M3	15	60	230/3	1750	42	H	SOOW	6AWG	1.08	N/A	N/A	N/A
6ANC1500M4	15	60	460/3	1750	21	H	SOOW	6AWG	1.08	N/A	N/A	N/A
6ANC2000M3	20	60	230/3	1750	52	G	SOOW	8AWG	.960	N/A	N/A	N/A
6ANC2000M4	20	60	460/3	1750	26	G	SOOW	8AWG	.960	N/A	N/A	N/A
6ANC3000M3	30	60	230/3	1750	70	G	SOOW	6AWG	1.08	N/A	N/A	N/A
6ANC3000M4	30	60	460/3	1750	35	G	SOOW	6AWG	1.08	N/A	N/A	N/A
6ANC4000M3	40	60	230/3	1750	100	G	SOOW	6AWG	1.08	N/A	N/A	N/A
6ANC4000M4	40	60	460/3	1750	50	G	SOOW	6AWG	1.08	N/A	N/A	N/A
6ANC5000M4	50	60	460/3	1750	61	G	SOOW	6AWG	1.08	N/A	N/A	N/A
6ANC6000M4	60	60	460/3	1750	71	G	SOOW	6AWG	1.08	N/A	N/A	N/A
8ANC5000M4	50	60	460/3	1750	60	G	SOOW	6AWG	1.08	N/A	N/A	N/A
8ANC6000M4	60	60	460/3	1750	74	G	SOOW	6AWG	1.08	N/A	N/A	N/A



Solids Handling Pumps

Models: 3ANC300/500/750,
4ANC2500/3000/4000/5000/6000
6ANC1000/1500/2000/3000/4000/5000/6000
8ANC5000/6000 Specifications

PHYSICAL DATA:

Discharge Size 3", 4", 6", 8"
Impeller Type Single Vane Enclosed, (3ANC), 2 VANE ENCLOSED (4ANC, 6ANC, 8ANC)
Cable Length 35'

LIQUID HANDLING:

MAXIMUM LIQUID TEMP. 140°F – Intermittent
104°F – Continuous
Acceptable PH range 6-8

TEMPERATURE:

Maximum Stator 155°C

TECHNICAL DATA:

Power Cord Type SOOW
Sensor Cord type SOOW
Motor Housing Cast Iron
Casing Cast Iron
Impeller Cast Iron
Motor Shaft 410 SS
Hardware SST
"O" rings Viton™
Mechanical Seals Inboard Mechanical Seal: Carbon-ceramic
Outboard Mechanical Seal: Silicon carbide

	3ANC300	3ANC500	3ANC750	4ANC2500	4ANC3000	4ANC4000	4ANC5000	4ANC6000	
Upper Bearing	6203	6304	6304	6209	6209	6310	6310	6310	
Lower Bearing	6206	6207	6207	3309	3309	3314	3314	3314	
	6ANC1000	6ANC1500	6ANC2000	6ANC3000	6ANC4000	6ANC5000	6ANC6000	8ANC5000	8ANC6000
Upper Bearing	6306	6306	6209	6209	6310	6310	6310	6310	6310
Lower Bearing	3209	3209	3209	3309	3314	3314	3314	3314	3314

Dimensions (inches)

Model	A	B	C	D	E	F
3ANC300	28.6"	2.3"	12.8"	15"	7.5"	8.5"
3ANC500	33.9"	4.0"	12.8"	15"	7.5"	8.5"
3ANC750	33.9"	4.0"	12.8"	15"	7.5"	8.5"
4ANC2500	46"	5.1"	21"	25.9"	9.0"	16.5"
4ANC3000	46"	5.1"	21"	25.9"	9.0"	16.5"
4ANC4000	46"	5.1"	21"	25.9"	9.0"	16.5"
4ANC5000	54.3"	5.1"	25.9"	26"	9.0"	16.5"
4ANC6000	54.3"	5.1"	25.9"	26"	9.0"	16.5"
6ANC1000	43.3"	8.9"	19.4"	24.6"	11"	14.8"
6ANC1500	43.3"	8.9"	19.4"	24.6"	11"	14.8"
6ANC2000	45.6"	8.9"	19.4"	24.6"	11"	14.8"
6ANC3000	48"	8.9"	19.4"	24.6"	11"	14.8"
6ANC4000	51.7"	10.7"	23.7"	30.3"	11"	18.5"
6ANC5000	56.3"	10.7"	23.7"	30.3"	11"	16.5"
6ANC6000	56.3"	10.7"	23.7"	30.3"	11"	16.5"
8ANC5000	53.5"	11"	24.4"	30.7"	13.5"	18.5"
8ANC6000	53.5"	11"	24.4"	30.7"	13.5"	18.5"

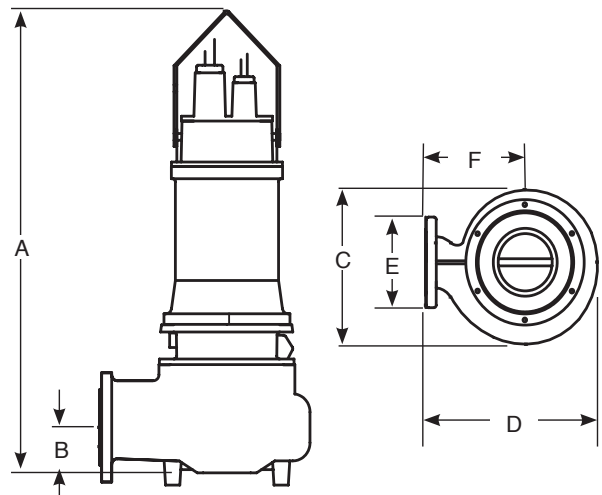



Solids Handling Pumps Models: 3ANC300/500/750 & 4ANC2500/3000/4000 Performance

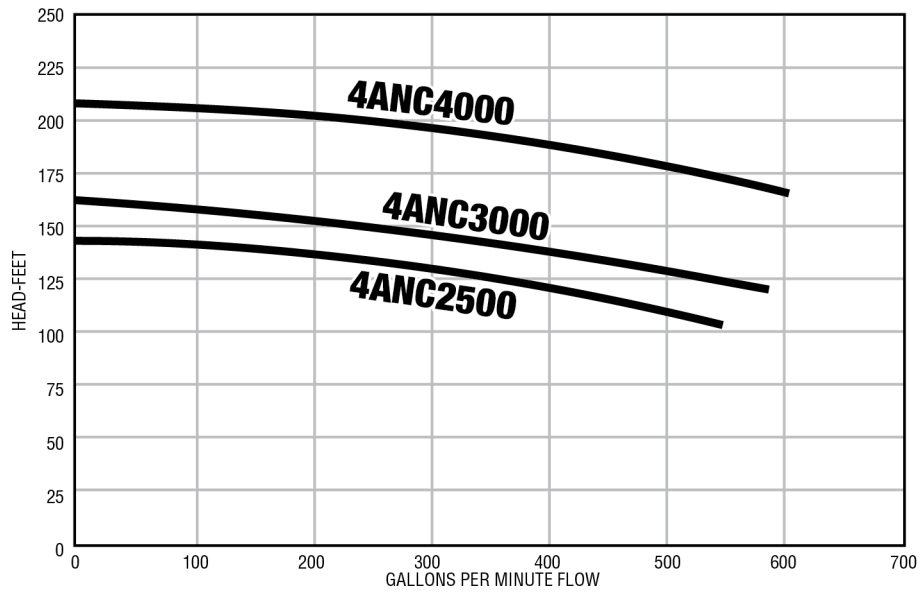
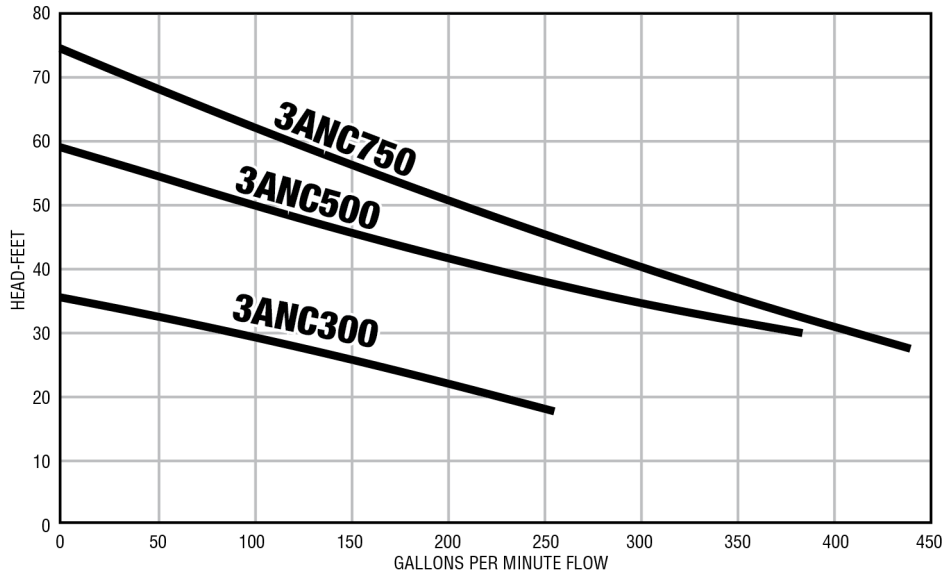



Solids Handling Pumps Models: 4ANC500/6000 and 6ANC1000/1500/2000 Performance

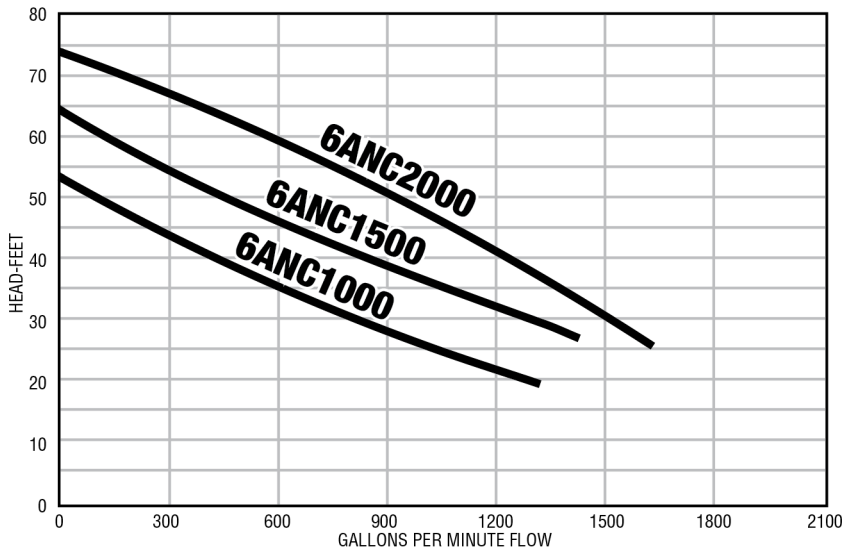
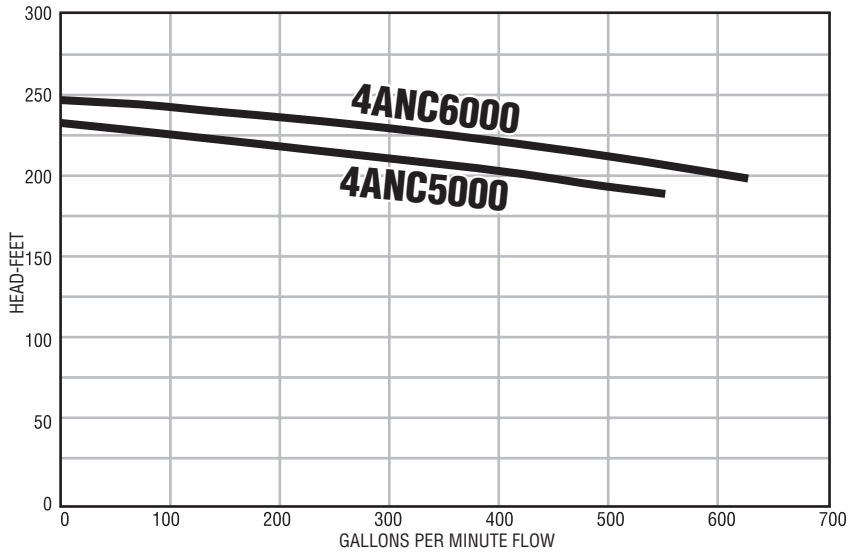



Solids Handling Pumps Models: 6ANC3000/4000/5000/6000 Performance

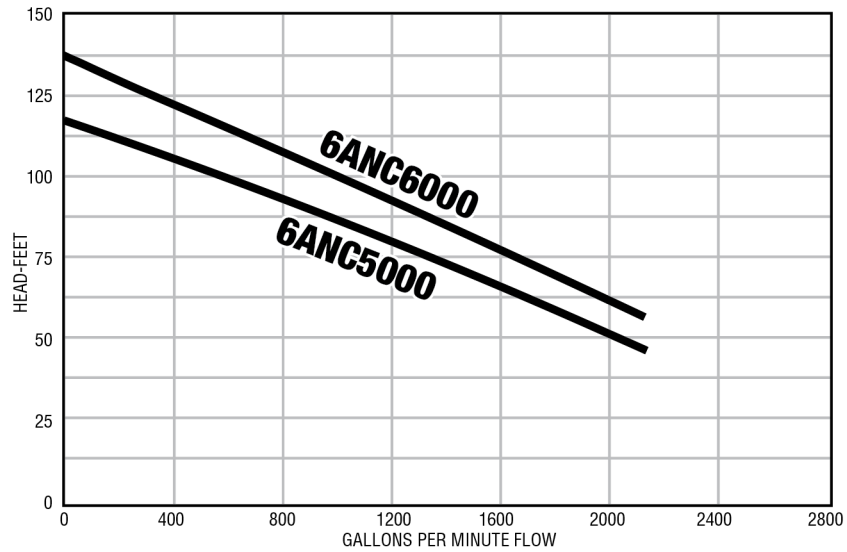
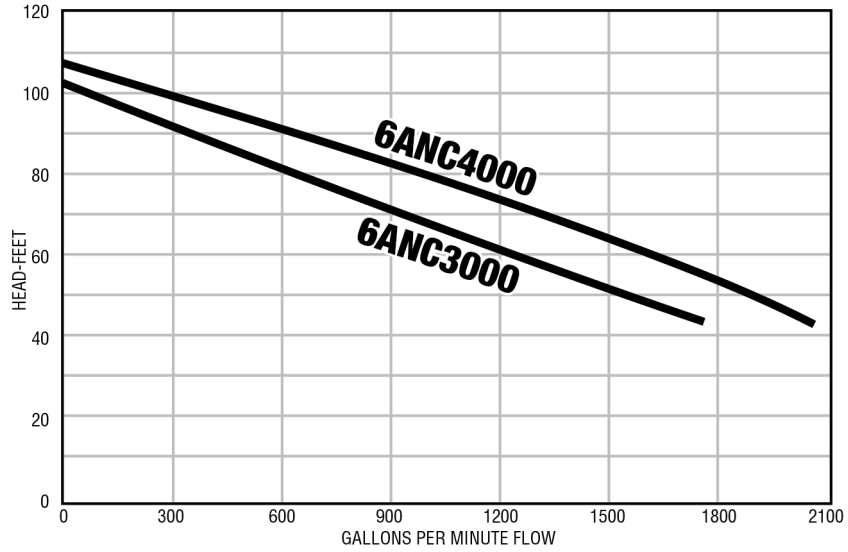



Solids Handling Pumps Models: 8ANC5000/6000 Performance

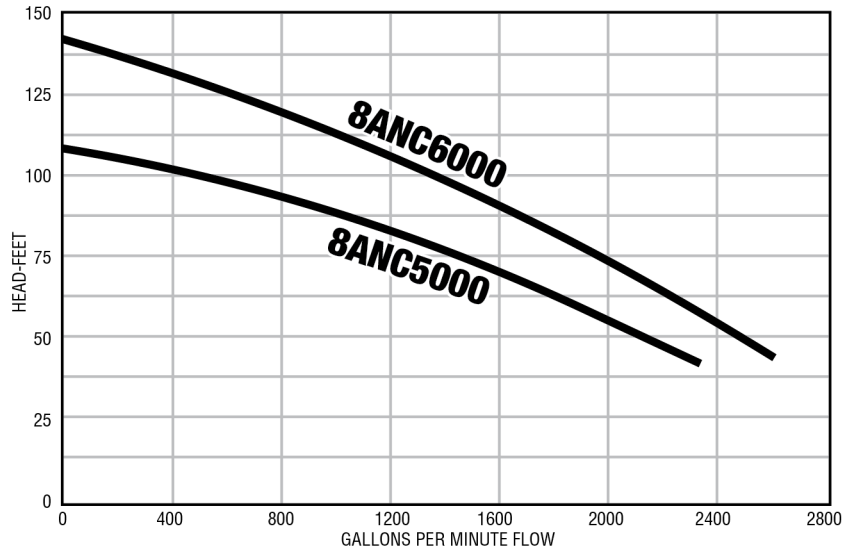



Solids Handling Pumps

Models: 3ANC300/500/750, 4ANC2500/3000/4000/5000/6000 6ANC1000/1500/2000/3000/4000/5000/6000 8ANC5000/6000 Receiving and Installation

Receiving Inspection

Upon receiving the pump, it should be inspected for damage or shortages. If damage has occurred, file a claim immediately with the company that delivered the pump. If the manual is removed from the packaging, do not lose or misplace.

Storage

Any product that is stored for a period longer than six (6) months from the date of purchase should be bench tested prior to installation. A bench test consists of, checking the impeller to assure it is free turning and a run test to assure the motor (and switch if provided) operate properly. Do not pump out of liquid.

WARNING IMPORTANT! A clearance under the pump for entrance of sewage solids must be a minimum of 3 inches to a maximum of 4.5 inches.

Submergence

The pump should always be operated in the submerged condition. See Minimum submergence and pump clearance levels below in figure 1

Installation

The sump or basin shall be sealed and vented in accordance with local plumbing codes. This pump is designed to pump domestic wastewater, nonexplosive and noncorrosive liquids and shall NOT be installed in locations classified as hazardous in accordance with the National Electrical Code (NEC) ANSI/ NFPA 70 or Canadian Electric Code (CEC). The pump should never be installed in a trench, ditch, or hole with a dirt bottom. The legs will sink into the dirt and the suction will become plugged.

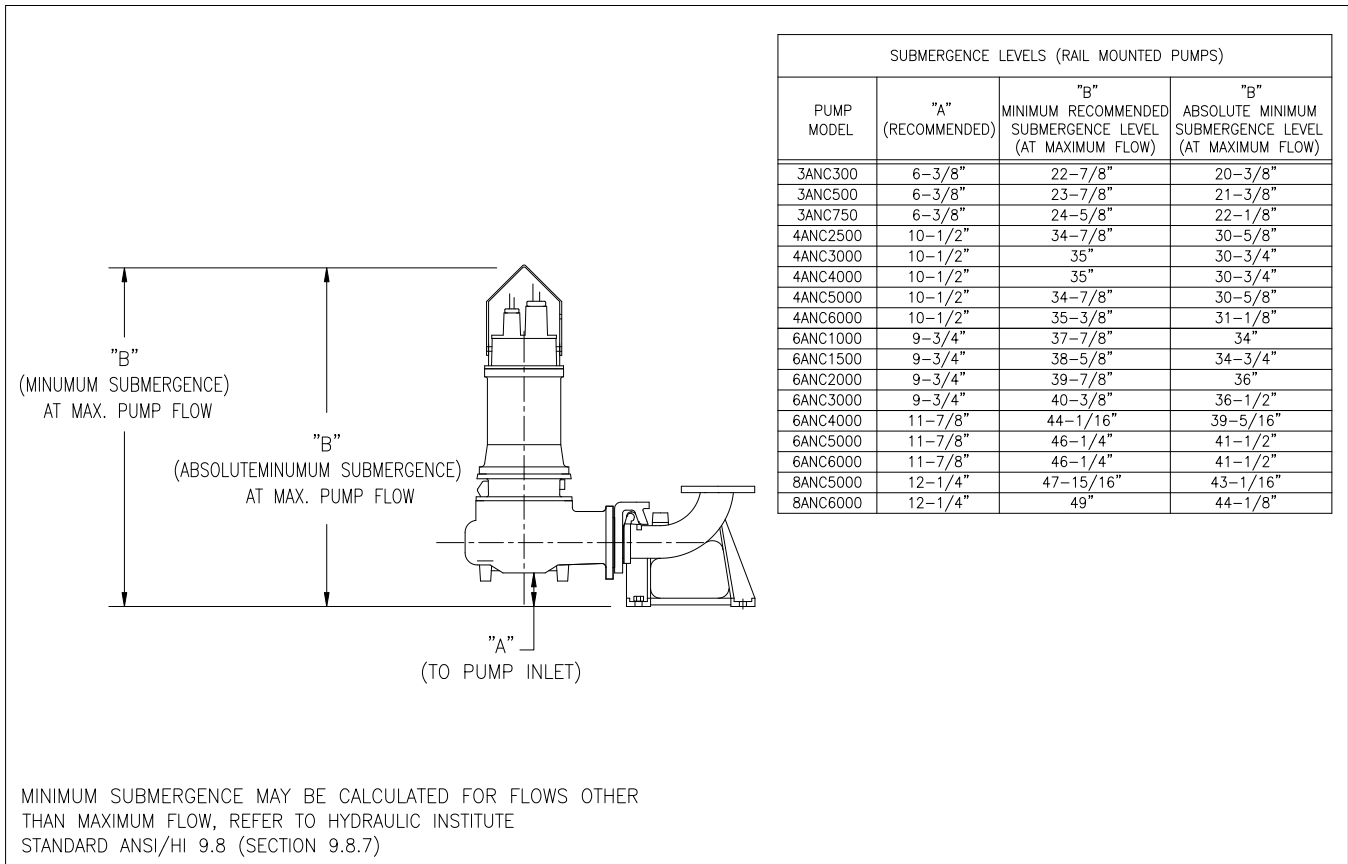



Solids Handling Pumps

Models: 3ANC300/500/750,
4ANC2500/3000/4000/5000/6000
6ANC1000/1500/2000/3000/4000/5000/6000
8ANC5000/6000 Installation

Discharge Piping

Install discharge piping or hose assembly to the pump. Discharge piping should be as short as possible and sized no smaller than the pump discharge. Do not reduce the discharge pipe size below that which is provided on the pump. Both a check valve and a shut-off valve are recommended for each pump. The check valve is used to prevent backflow into the sump. The shut-off valve is used to manually stop system flow during pump servicing. Be sure the discharge pipe has a 1/8" diameter hole approx. 5" from end nearest volute and oriented towards the pump body.

Control Panel

All pumps require a control panel. Single/phase models require start components in panel.

Motor Seal Failure Warning

The seal chamber is oil filled and provided with moisture sensing probes to detect water leakage through the lower shaft seal. The probes can also detect moisture present in the upper motor housing.

The presence of water energizes a red seal leak warning light at the control panel. This is a warning light only, and does not stop the motor. It indicates a leak has occurred and the pump must be repaired. Normally, this indicates the outboard seal has leaked. Allowing the unit to operate too long after the warning could cause upper seal leakage along with motor failure.

The resistance across the moisture sensing (seal failure) probes should be checked after a seal leak warning light has lit. This can be done by disconnecting the red and orange control wires from the control panel, and measuring the resistance with an ohmmeter between the wires.

The reading should be 100,000 ohms or greater. If the measured values are below those indicated above, then the pump may have a lower seal failure and require service.

Note: Failure to use proper circuitry and to connect the motor overheat protection in the control panel would negate all warranties.

Motor power cord, control cord and cord cap assembly Each motor power cord has 4 conductors: white, black, red and green. See Figure 3 for internal wiring schematic.

Note: Rotation should be clockwise when observed from the top of the pump. This can be checked by noting which direction the pump torque is upon initial starting. A properly rotating pump will torque counterclockwise upon start.

The control cable has 5 conductors: black, white, red, yellow and green. White and black connect to the heat sensor terminals; red and yellow connect to the seal failure leads; and the green connects to the ground in the control panel. (Figure 3)

Note: Each cable has a green ground wire and must be properly grounded per the National Electric Code and local codes.

Electrical Motor Controls

All electrical controls and motor starting equipment should be as specified in these instructions.

Pre-operation

CHECK VOLTAGE AND PHASE

Before operating pump, check to make sure that voltage and phase information stamped on the pump's identification plate matches the available power.

CHECK PUMP ROTATION

Before putting pump into service for the first time, the motor rotation must be checked. Improper motor rotation can result in poor pump performance and can damage the motor and/or pump.

IDENTIFICATION PLATE

Note the numbers on the pumps identification plate and record at the end of this manual for future reference.



Solids Handling Pumps

Models: 3ANC300/500/750,
4ANC2500/3000/4000/5000/6000
6ANC1000/1500/2000/3000/4000/5000/6000
8ANC5000/6000 Installation and Service

Electrical Connections



Turn circuit breaker off before wiring the pump to the control panel.

Always rely upon a Certified Electrician for installation.

Level Control

It is recommended that the level control float should be set to insure that the liquid in the sump never drops below the top of the motor housing. The level control should have adequate clearance so it cannot hang up in its swing and that the pump is completely submerged when the level control is in the "Off" mode. Minimum tether length is 3.50".

DO NOT USE THE POWER CABLE TO LIFT PUMP.

Thermal Protection

Motors are protected by a thermo-overload or thermo sensor depending on the model and single or three phase.

Pre-Operation

1. Check Voltage and Phase compare to the voltage and phase information stamped on the pump name plate.
2. Check Pump Rotation - Improper motor rotation can result in poor pump performance and can damage the motor and/or pump. Check rotation by momentarily applying power and observe the "kickback". Kickback should always be in a counter-clockwise direction as viewed from motor end or opposite to impeller rotation. Incorrect rotation for Single-Phase pumps is unlikely. If the rotation is incorrect contact factory.
3. Name Plate - Record the information from the pump name plate for future reference.
4. Pump-Down Test - Be sure pump has been plugged in, lowered into the basin or sump, check the system by filling with liquid and allowing the pump to operate through its pumping cycle. The time needed to empty the system, or pump-down time along with the volume of water, should be recorded.

Cooling Oil Recommended Supplier/Grade	
BP	Enerpar SE100
Conoco	Pale Paraffin 22
Mobile	D.T.E. Oil Light
Shell Canada	Transformer-10
Texaco	Diala-Oil-AX



Solids Handling Pumps
Models: 3ANC300/500/750,
4ANC2500/3000/4000/5000/6000
6ANC1000/1500/2000/3000/4000/5000/6000
8ANC5000/6000 Installation and Service

Pump Model	HP	Seal Housing Oil Level (Qt.)	Motor Housing Oil Level (Qt.)
3ANC300M3	3	1.69	4.76
3ANC300M4	3	1.69	4.76
3ANC500M3	5	3.7	5.28
3ANC500M4	5	3.7	5.28
3ANC750M3	7.5	3.7	5.28
3ANC750M4	7.5	3.7	5.25
4ANC2500M4	25	10.57	31.91
4ANC3000M4	30	10.57	31.91
4ANC4000M4	40	10.57	31.91
4ANC5000M4	50	10.57	66.57
4ANC6000M4	60	10.57	66.57
6ANC1000M3	10	9.51	24.3
6ANC1000M4	10	9.51	24.3
6ANC1500M3	15	9.51	24.3
6ANC1500M4	15	9.51	24.3
6ANC2000M4	20	10.57	24.3
6ANC3000M4	30	10.57	31.91
6ANC4000M4	40	10.57	31.91
6ANC5000M4	50	10.57	66.57
6ANC6000M4	60	10.57	66.57
8ANC5000M4	50	10.57	66.57
8ANC6000M4	60	10.57	66.57



Solids Handling Pumps
Models: 3ANC300/500/750,
4ANC2500/3000/4000/5000/6000
6ANC1000/1500/2000/3000/4000/5000/6000
8ANC5000/6000 Installation and Service

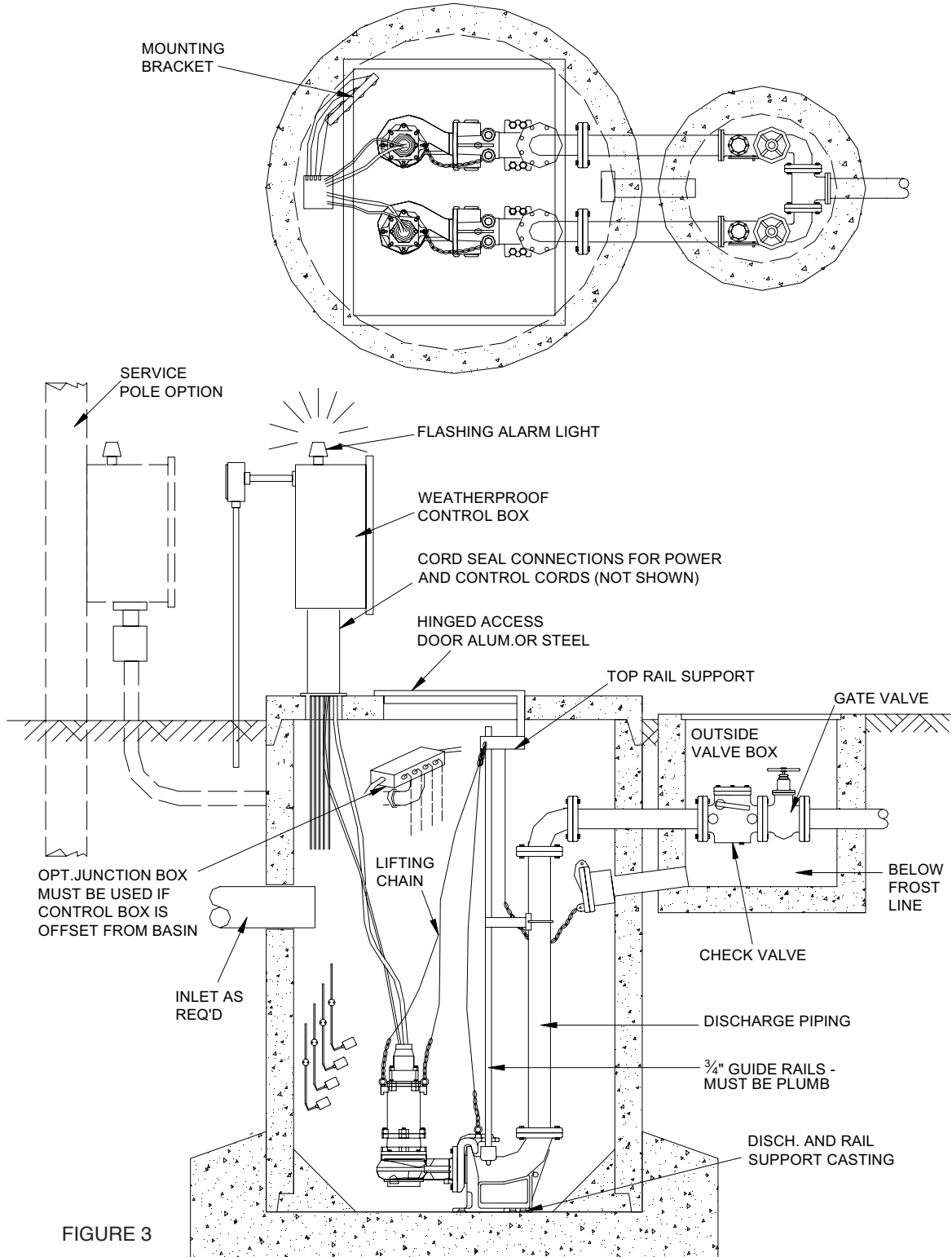

FIGURE 3

Figure 3
TYPICAL INSTALLATION FOR DUPLEX SYSTEM WITH CONCRETE BASIN AND OUTSIDE VALVE BOX



Solids Handling Pumps

Models: 3ANC300/500/750,
4ANC2500/3000/4000/5000/6000
6ANC1000/1500/2000/3000/4000/5000/6000
8ANC5000/6000 Wiring

WIRING CONNECTIONS

1. All electrical wiring must be in accordance with local code and only qualified electricians should make the installations.
2. Three phase pumps - instructions for wiring to control panel will be included with control panel.
3. All wires should be checked for shorts to ground with an ohmmeter or megger after the connections are made. This is IMPORTANT, as one grounded wire can cause failure of the pump, control panel or personal injury.

Wiring Diagram (Dual/Single Voltage)

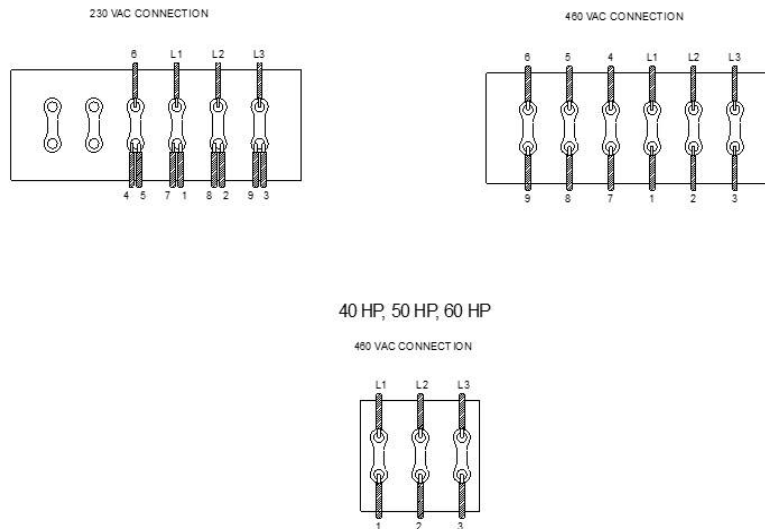



Solids Handling Pumps

Models: 3ANC300/500/750, 4ANC2500/3000/4000/5000/6000 6ANC1000/1500/2000/3000/4000/5000/6000 8ANC5000/6000 Troubleshooting

⚠ WARNING

Always discount the pump from the electrical power source before handling. If the system fails to operate properly, carefully read instructions and perform maintenance recommendations. If operating problems persist, the following chart may be of assistance in identifying and correcting them.

SYMPTOM	POSSIBLE CAUSES	CORRECTIVE ACTION
Red light comes on at control box	<ol style="list-style-type: none"> This indicates some water has leaked Replace the lower seal past the lower seal and has entered the seal chamber and made contact with the electrode probe. 	<ol style="list-style-type: none"> Replace the lower seal
Overload trips at control box and alarm buzzer or due to high water level in basin	<ol style="list-style-type: none"> Impeller may be partially clogged with foreign objects. Component in the control box may be faulty. Pump has some damaged. 	<ol style="list-style-type: none"> Check impeller for freedom of operation, security and condition Clean impeller cavity and inlet of any obstruction. Check control box, if need repair it. Check pump, if need repair it.
Yellow run light stays on continuously	<ol style="list-style-type: none"> H-O-A switch may be in the hand position Level control switch may have failed causing pump to continue to operate when water is below lower control. Impeller may be partially clogged causing pump to operate at very reduced capacity. Gate valve or check valve may be clogged causing low pump flow. Pump may be air clogged. 	<ol style="list-style-type: none"> Reposition pump or clean basin as required to provide adequate clearance for float Disconnect level control. Set ohmmeter for a low range, such as 100 ohms full scale and connect to level control leads. Actuate level control manually and check to see that ohmmeter shows zero ohms for closed switch and full scale for open switch (Float Switch) Check impeller for freedom of operation, security, and condition. Clean impeller cavity and inlet of any obstruction Remove and examine check valve for proper Installation and freedom of operation Loosen union slightly to allow trapped air to escape. Verify that turn-off level of switch is set so that impeller cavity is always flooded. Clean vent hole.
Circuit breaker trips with control	<ol style="list-style-type: none"> Excessive load probably caused by a short in the motor or control box If this condition happens after an electrical storm, motor or control box may be damaged by lightning. 	<ol style="list-style-type: none"> Check out instructions given box before pulling pump Reset breaker by pushing completely down on handle then back to ON position. If breaker trips again in a few seconds it indicates.
Pump is noisy and pump rate is low	<ol style="list-style-type: none"> Impeller may be partially clogged with some foreign objects causing noise and overload on the motor. Impeller may be rubbing on wear ring due to bent shaft or misalignment. Pump may be operating too close to shut-off 	<ol style="list-style-type: none"> Check impeller for freedom of operation, security, and condition. Clean impeller cavity and inlet of any obstruction. If need replace shaft Check if the pump is operating too close to shut-off.
Grease and solids have accumulated around pump and will not pump out of basin.	<ol style="list-style-type: none"> Lower control switch may be set too high. Trash and grease may have accumulated around floats causing pump to operate erratically 	<ol style="list-style-type: none"> Check and reset the control switch Run pump on hand operation for several minutes with small amount of water running into amount of water running into basin to clean out solids and grease.



Solids Handling Pumps Models: 3ANC300M3-35, 3ANC500M3-35 and 3ANC750M3-35 Repair Parts

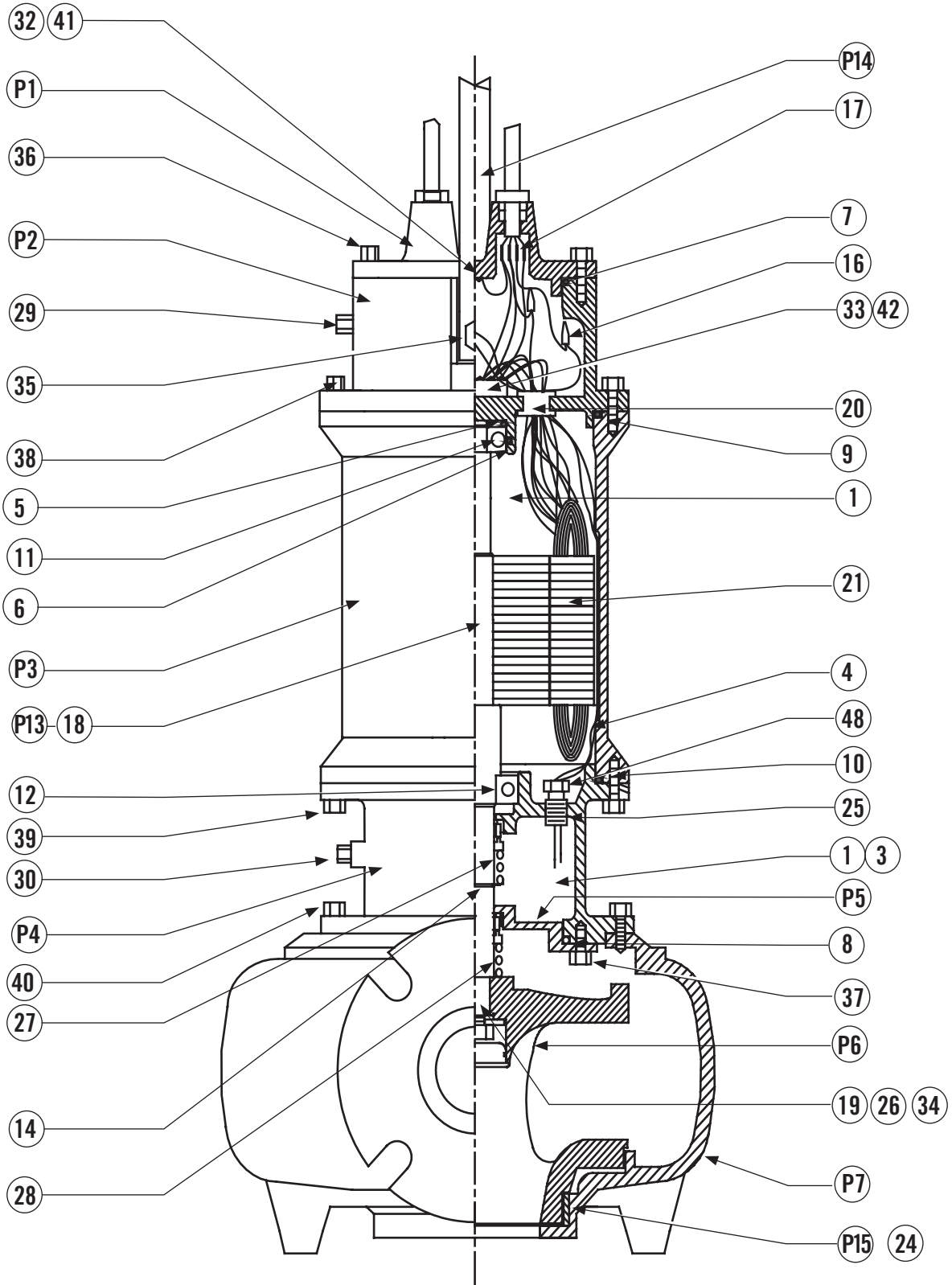



Solids Handling Pumps

Models: 3ANC300M3-35, 3ANC500M3-35 and 3ANC750M3-35 Repair Parts List

Model	No. Part Description	Part No. for pump models			Qty
		3ANC300M3	3ANC500M3-35	3ANC750M3-35	
P1	CABLE COVER DISK	3DTFL02008	3DTFL05108	3DTFL05109	1
P2	CABLE COVER	3TAFLO2005	3TAFLO5106	3TAFLO5106	1
P3	SLEEVE	3CMFL02GP0	3CMFL03GP0	3CMFL05GP0	
1					
P4	CRACK CASE	3CAFL02000	3CAFLO5100	3CAFL05100	1
P5	CRACK CASE COVER	3TFCFL2001	3TCFLO5102	3TCFL05102	1
P6	IMPELLER	3IMFL02763	3IMFL057H0	3IMFLO5764	1
P7	HOUSING	3CCFL276G2	3CCFL5476H	3CCFL5476H	1
P13	SHAFT WITH ROTOR	3FROL762D1	3FROL765D1	3FROL765D1	1
P14	HANDLE	3MA43M1264	3MA43M1717	3MA43M1717	1
P15	WEAR RING	3ADB021093	3ADB014046	3ADB014046	1
1	OIL (L)	1ACLSAE101	1ACLSAE101	1ACLSAE101	2.5 L
4	WIRE	1ALC0022NB	1ALC0022NB	1ALC0022NB	2
5	O-RING	1ORN022379	1ORN022775	1ORN022775	1
6	O-RING	1ORN022379	1ORNO32777	1ORNO32777	1
7	O-RING	1ORN024274	1ORN034976	1ORN034976	1
8	O-RING	1ORN035471	1ORN035979	1ORN035979	1
9	O-RING	1ORN036271	1ORN036271	1ORN036271	1
10	O-RING	1ORN036373	1ORN036870	1ORN036870	1
11	UPPER BEARING	1BA7620321	1BA7630424	1BA7630424	1
12	LOWER BEARING	1BA7620626	1BA7620727	1BA7620727	1
14	TRU-ARC LOCK	1CT914003	1CT9141251	1CT9141251	1
16	THREADED CONNECTOR	1COE2214R0	1COE2214R0	1COE2214R0	10
18	WEDGE	1CU10100W1	3CU8021208	3CU8021208	
1					
19	WEDGE	3CU4026893	3CU4021067	3CU4021067	
1					
20	WIRE-PASS PACKAGING	1EPN000A70	1EPN000176	1EPN000176	
1					
21	STATOR	1ESE020404	1ESE050404	1ESE050404	1
24	SCREW SET	1PRR40204L0	-	-	2
25	SPARK PLUG SENSOR	3BU0030203	3BU0030203	3BU0030203	2
26	FLAT WASHER	1RO40300P8	1RO40400P9	1RO40400P9	3
27	UPPER SEAL	1SEE080013	1SEE100014	1SEE100014	1
28	LOWER SEAL	1SEE080013	1SEE100014	1SEE100014	1
29	MALE PLUG	1TMB01NP09	1TMB01NP09	1TMB01NP09	1
30	MALE PLUG	1TMB02NP00	1TMB02NP00	1TMB02NP00	3
32	FILLISTER HEAD SCREW	1TO83M02G5	1TO83M02G5	1TO83M02G5	1
33	FILLISTER HEAD SCREW	-	1TO83M06G1	1TO83M06G1	2
34	HEXAGONAL SCREW	1TO40306E1	1TO40408E5	1TO40408E5	1
35	HEXAGONAL SCREW	1TO40306E1	1TO40408E5	1TO40408E5	2
36	HEXAGONAL SCREW	1TO40206E9	1TO40406E5	1TO40406E5	4
37	HEXAGONAL SCREW	1TO40206E9	1TO40206E9	1TO40206E9	6
38	HEXAGONAL SCREW	1TO45M06E5	1TO45M08E8	1TO45M08E8	4
39	HEXAGONAL SCREW	1TO45M06E5	1TO45M08E8	1TO45M08E8	6
40	HEXAGONAL SCREW	1TO45M06E5	1TO45M08E8	1TO45M08E8	6
41	BUTTED SEAM TERMINAL	1ZAC3M14J3	1ZAC3M12J0	1ZAC3M12J0	1



Solids Handling Pumps

Models: 4ANC2500M4-35 & 4ANC3000M4-35
Repair Parts

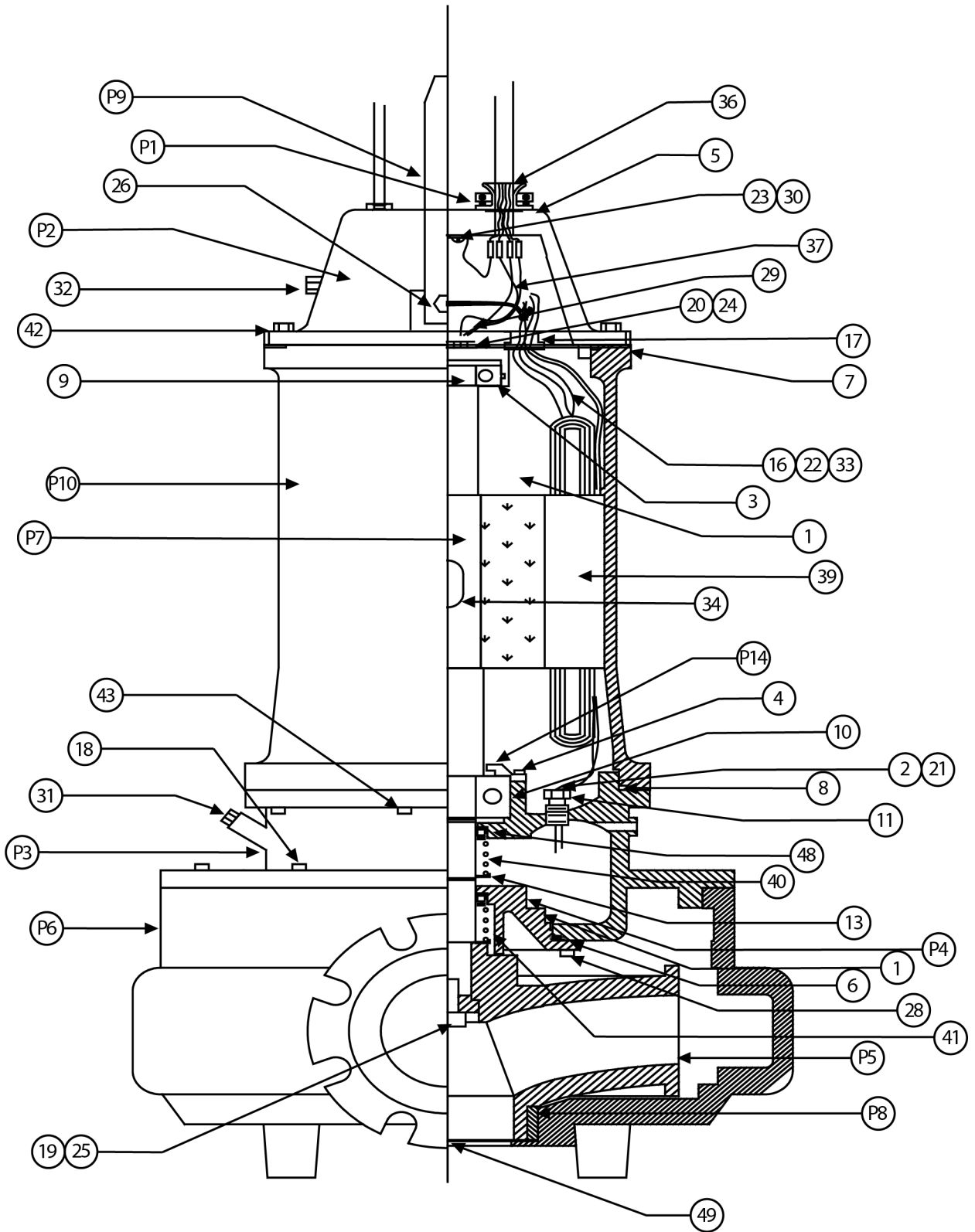



Solids Handling Pumps

Models: 4ANC2500M4-35 & 4ANC3000M4-35

Repair Parts List

MODEL No.	QTY.	PART No.	DESCRIPTION
P2	1	3TAF75630	CORD CAP 35'
P3	1	3CAF730AP0	BEARING HOUSING
P4	1	3TCFL10007	SEAL PLATE
P5	1	3IMFL30AP0	IMPELLER
P6	1	3CCFL30AP6	VOLUTE CASE
P7	1	3FR0L003W1	SHAFT W/ROTOR
P8	1	3ADB401266	WEAR RING
P9	1	3MA4L30AP8	HANDLE
P10	1	3CMFL20GP0	MOTOR HOUSING
P14	1	3TBFL30200	BEARING COVER
1	17	1ACL38KVD5	OIL (l)
2	1.8	1ALC0022N8	MOISTURE SENSOR WIRE
3	1	1ORN023778	O-RING
4	4	1TO45M08E8	HEX HEAD CAP SCREW
5	1	1ORN036373	O-RING
6	1	1ORN036373	O-RING
7	1	1ORN037376	O-RING
8	1	1ORN037873	O-RING
9	1	1BA7620904	UPPER BEARING
10	1	1BA7330907	LOWER BEARING
11	2	3BU0030203	MOISTURE SENSOR
13	1	1CT9141759	SNAP RING
4	4	1COE2214R0	THREADED CONNECTOR 440V
16	6	1COC0016Z9	BUTT CONNECTOR
17	2	1EPN000176	WIRE PASS THROUGH GASKET
18	16	1TO40410E6	HEX HEAD CAP SCREW
19	2	1RO40615P0	IMPELLER WASHER
20	1	1TA0060604	CONNECTIONS TABLET
21	2	1TDE558501	ELECTRICAL TERMINAL
22	3	1TE0011003	THERMOSTAT
23	1	1TO83M02G5	FILLISTER HEAD SCREW
24	2	1TO83M06G1	FILLISTER HEAD SCREW
25	1	1TO40610E9	HEX HEAD CAP SCREW
26	2	1TO40408E5	HEX HEAD CAP SCREW
27	6	1TO40206E9	HEX HEAD CAP SCREW
28	0.2	1TCC020004	FLEXIBLE PIPING (m)
29	2	1ZAC3M0605	EYELET TERMINAL
30	3	1TMB02NP00	PIPE PLUG
31	1	1TMB01NP09	PIPE PLUG
33	1	3CU8039844	KEY
34	1	3CU4031696	KEY
37	16.4	1CAV040603 220V	
39	1	1ESE200404	STATOR
40	1	1SEE140010	UPPER SEAL
41	1	1SEE140010	LOWER SEAL
42	8	1TO45M08E8	HEX HEAD CAP SCREW
43	8	1TO45M08E8	HEX HEAD CAP SCREW
49	2	1PR40204L0	SET SCREW

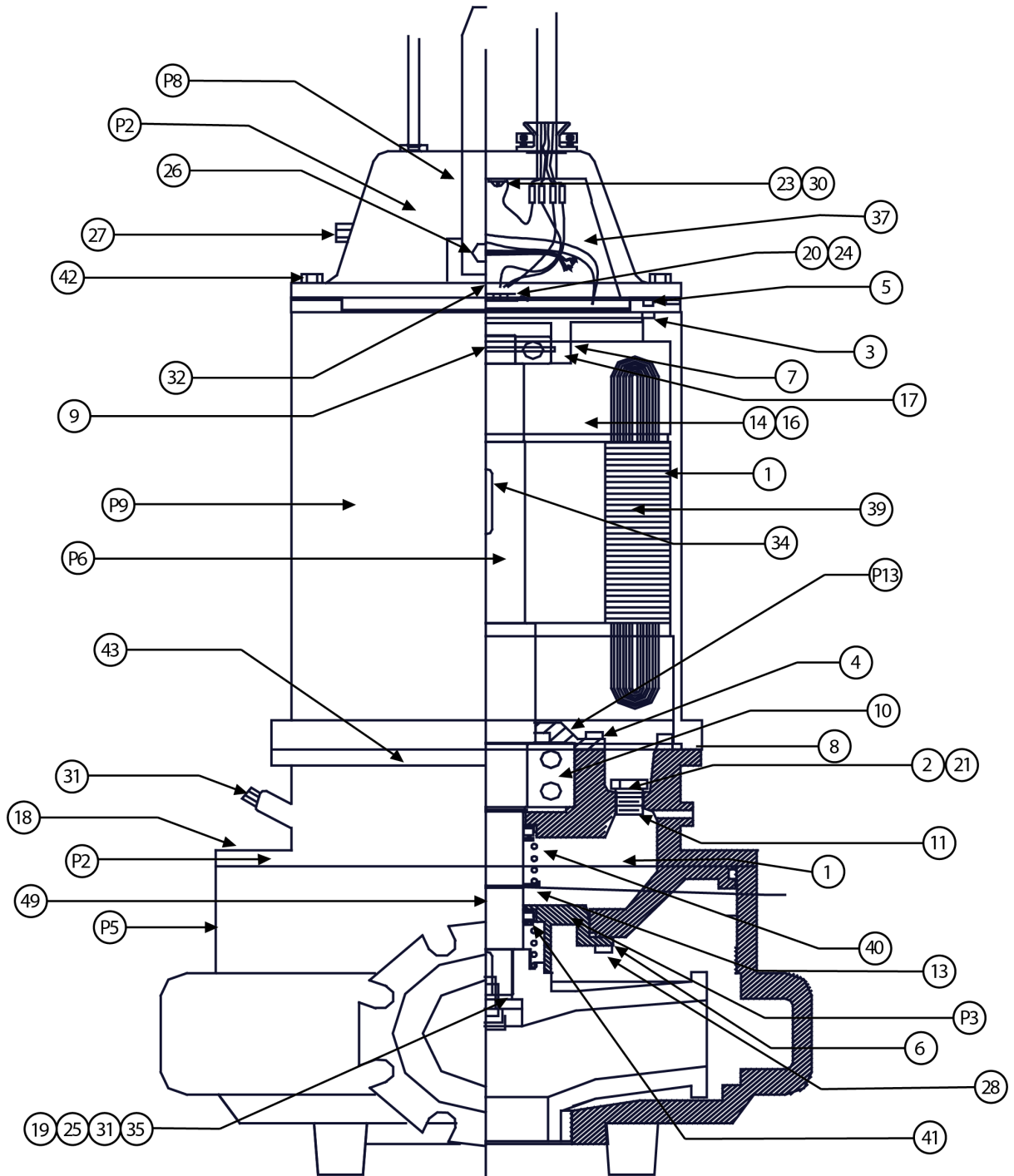



Solids Handling Pumps

Models: 4ANC4000M4-35

Repair Parts List

MODEL No.	QUANTITY	PART NO.	DESCRIPTION
P1	1	3TAF140224	CORD CAP 35'
P2	1	3CAF110401	BEARING HOUSING
P3	1	3TCFL40001	SEAL PLATE
P4	1	3IMFL40AP6	IMPELLER
P5	1	3CCFL10407	VOLUTE CASE
P6	1	3FR0L204W0	SHAFT W/ROTOR
P7	1	3ADBL40AP2	WEAR RING
P8	1	3MA4022693	HANDLE
P9	1	3CMFL60202	MOTOR HOUSING
P13	1	3TBFL40008	BEARING COVER
1	4	1ACL38KVD5	OIL (I)
2	2	1ALC0022N8	MOISTURE SENSOR WIRE
3	1	1ORN024578	O-RING
4	4	1TO45M06E5	HEX HEAD CAP SCREW
5	1	1ORN045371	O-RING
6	1	1ORN036474	O-RING
7	1	1ORN045077	O-RING
8	1	1ORN046070	O-RING
9	1	1BA7631005	UPPER BEARING
10	1	1BA7331402	LOWER BEARING
11	2	3BU0030203	MOISTURE SENSOR
13	1	1CT9142504	SNAP RING
16	6	1COC0016Z9	BUTT CONNECTOR
17	2	1EPN000176	WIRE PASS THROUGH GASKET
18	16	1TO40312E8	HEX HEAD CAP SCREW
19	1	3RO4L30006	IMPELLER WASHER
20	1	9BD1643226	CONNECTION BLOCK
21	2	1TDE558501	ELECTRICAL TERMINIAL
23	1	1TO83M04G8	FILLISTER HEAD SCREW
24	2	1TO83M06G1	FILLISTER HEAD SCREW
25	1	1TO40510E8	HEX HEAD CAP SCREW
26	2	1TO40712E4	HEX HEAD CAP SCREW
27	8	1TO40310E5	HEX HEAD CAP SCREW
28	6	1TO40208E2	HEX HEAD CAP SCREW
30	2	1ZAC3M0605	EYELET TERMINAL
31	3	1TMB02NP00	PIPE PLUG
32	2	1TMB02NP00	PIPE PLUG
34	1	3CU8032552	KEY
35	1	3CU4031696	KEY
39	1	1ESE300404	STATOR
40	1	1SEE200017	UPPER SEAL
41	1	1SEE200017	LOWER SEAL
42	8	1TO40306E1	HEX HEAD CAP SCREW
43	8	1TO40206E9	HEX HEAD CAP SCREW
49	2	1PR40204L0	SET SCREW



Solids Handling Pumps

Models: 4ANC5000M4-35 & 4ANC6000M4-35
Repair Parts

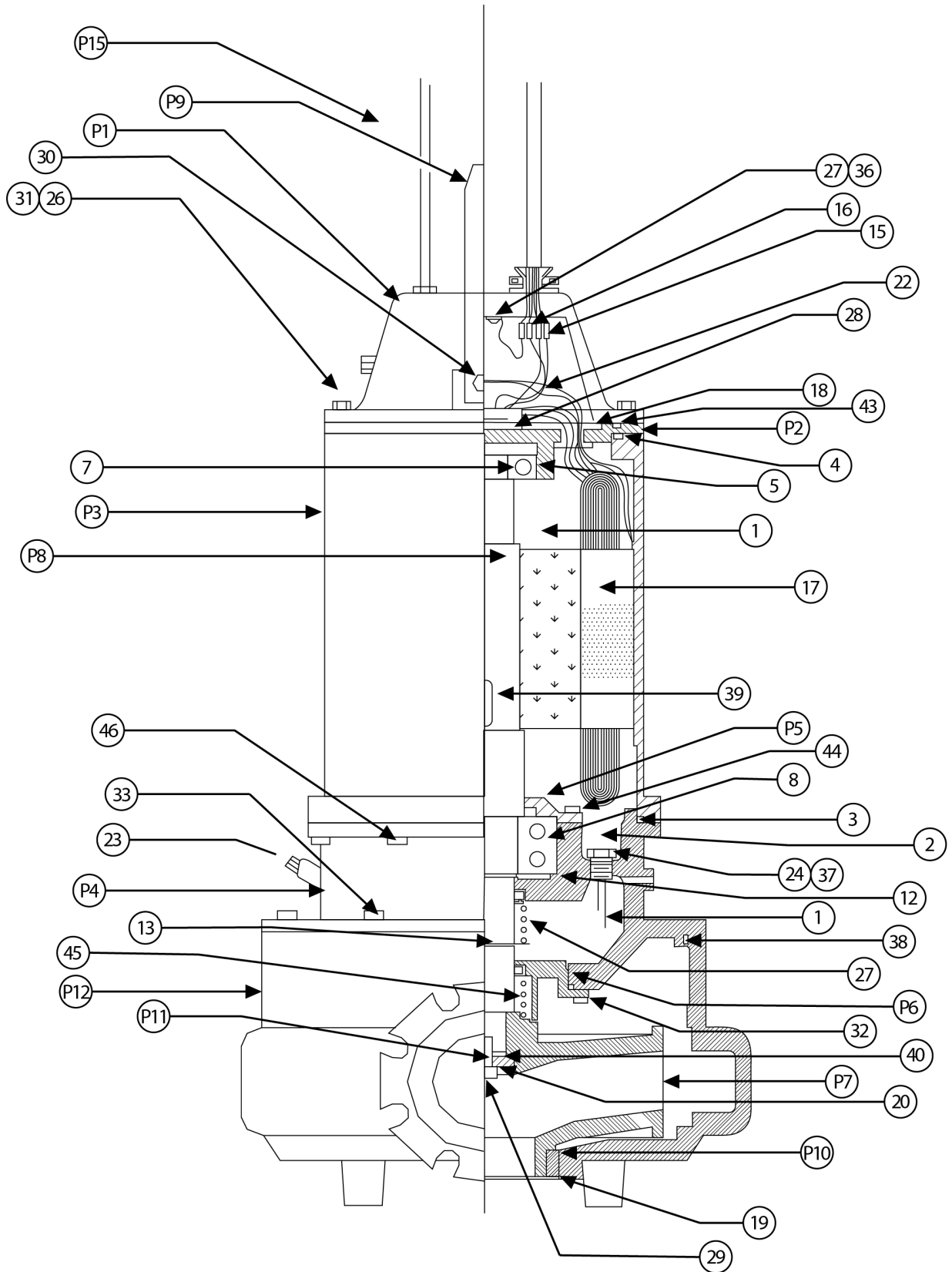



Solids Handling Pumps

Models: 4ANC5000M4-35 & 4ANC6000M4-35

Repair Parts List

MODEL	QTY	PART NUMBER	QTY	PART NUMBER	DESCRIPTION
P1	1	3TAFL40224	1	3TAFL40224	CORD CAP 35'
P2	1	3TMFL40001	1	3TMFL40001	UPPER BEARING PLATE
P3	1	3CMFL206W0	1	3CMFL206W0	MOTOR HOUSING
P4	1	3CAFL105A0	1	3CAFL105A0	BEARING HOUSING
P5	1	3TBFL40008	1	3TBFL40008	BEARING COVER
P6	1	3TCFL40001	1	3TCFL40001	SEAL PLATE
P7	1	3IMFL50AP0	1	3IMFL60AP0	IMPELLER
P8	1	3FR0L206W0	1	3FR0L206W0	SHAFT W/ROTOR
P9	1	3MA4022693	1	3MA4022693	HANDLE
P10	1	3ADBL40AP2	1	3ADBL40AP2	WEAR RING
P11	1	3RO4L30006	1	3RO4L30006	IMPELLER WASHER
P12	1	3CCFL10407	1	3CCFL10407	VOLUTE CASE
1	30.5	1ACL38KVD5	30.5	1ACL38KVD5	OIL (I)
2	2.3	1ALC0022N8	2	1ALC0022N8	MOISTURE SENSOR WIRE
3	1	1ORN045777	1	1ORN045777	O-RING
4	1	1ORN044977	1	1ORN044977	O-RING
5	1	1ORN024578	1	1ORN024578	O-RING
6	1	1ORN036474	1	1ORN036474	O-RING
7	1	1BA7631005	1	1BA7631005	UPPER BEARING
8	1	1BA7331402	1	1BA7331402	LOWER BEARING
12	1	1CT9512759	1	1CT9512759	SNAP RING
13	1	1CT9142504	1	1CT9142504	SNAP RING
15	4	1COCA416A1	4	1COCA416A1	THREADED CONNECTOR
17	1	1ESE400404	1	1ESE400404	STATOR
18	1	1EPN000176	1	1EPN000176	WIRE PASS THROUGH GASKET
19	2	1PR40204L0	2	1PR40204L0	SET SCREW
20	1	1PR40304L2	1	1PR40304L2	SET SCREW
21	1	1SEE200017	1	1SEE200017	UPPER SEAL
22	1	9BD1643226	1	9BD1643226	CONNECTION BLOCK
23	5	1TMB02NP00	5	1TMB02NP00	MALE PLUG
24	2	1TDE558501	2	1TDE558501	ELECTRICAL TERMINAL
26	2	1TO40206L0	2	1TO40206L0	ALLEN SCREW
27	1	1TO83M04G8	1	1TO83M04G8	FILLISTER HEAD SCREW
28	2	1TO83M06G1	2	1TO83M06G1	FILLISTER HEAD SCREW
29	1	1TO40712E4	1	1TO40712E4	HEX HEAD CAP SCREW
30	2	1TO40510E8	2	1TO40510E8	HEXAGONAL SCREW
31	8	1TO40312E8	8	1TO40312E8	HEX HEAD CAP SCREW
32	6	1TO40206E9	6	1TO40206E9	HEX HEAD CAP SCREW
33	16	1TO40312E8	16	1TO40312E8	HEX HEAD CAP SCREW
36	2	1ZAC3M0605	2	1ZAC3M0605	EYELET TERMINAL
37	2	3BU0030203	2	3BU0030203	MOISTURE SENSOR
38	1	1ORN046070	1	1ORN046070	O-RING
39	1	3CU8051961	1	3CU8051961	KEY
40	1	3CU4031696	1	3CU4031696	KEY
43	1	1ORN045077	1	1ORN045077	O-RING
44	4	1TO40208E2	4	1TO40208E2	HEX HEAD CAP SCREW
45	1	1SEE200017	1	1SEE200017	LOWER SEAL
46	8	1TO40312E8	8	1TO40312E8	HEX HEAD CAP SCREW



Solids Handling Pumps

Models: 6ANC1000M3-35, 6ANC1500M3-35
and 6ANC2000M4-35

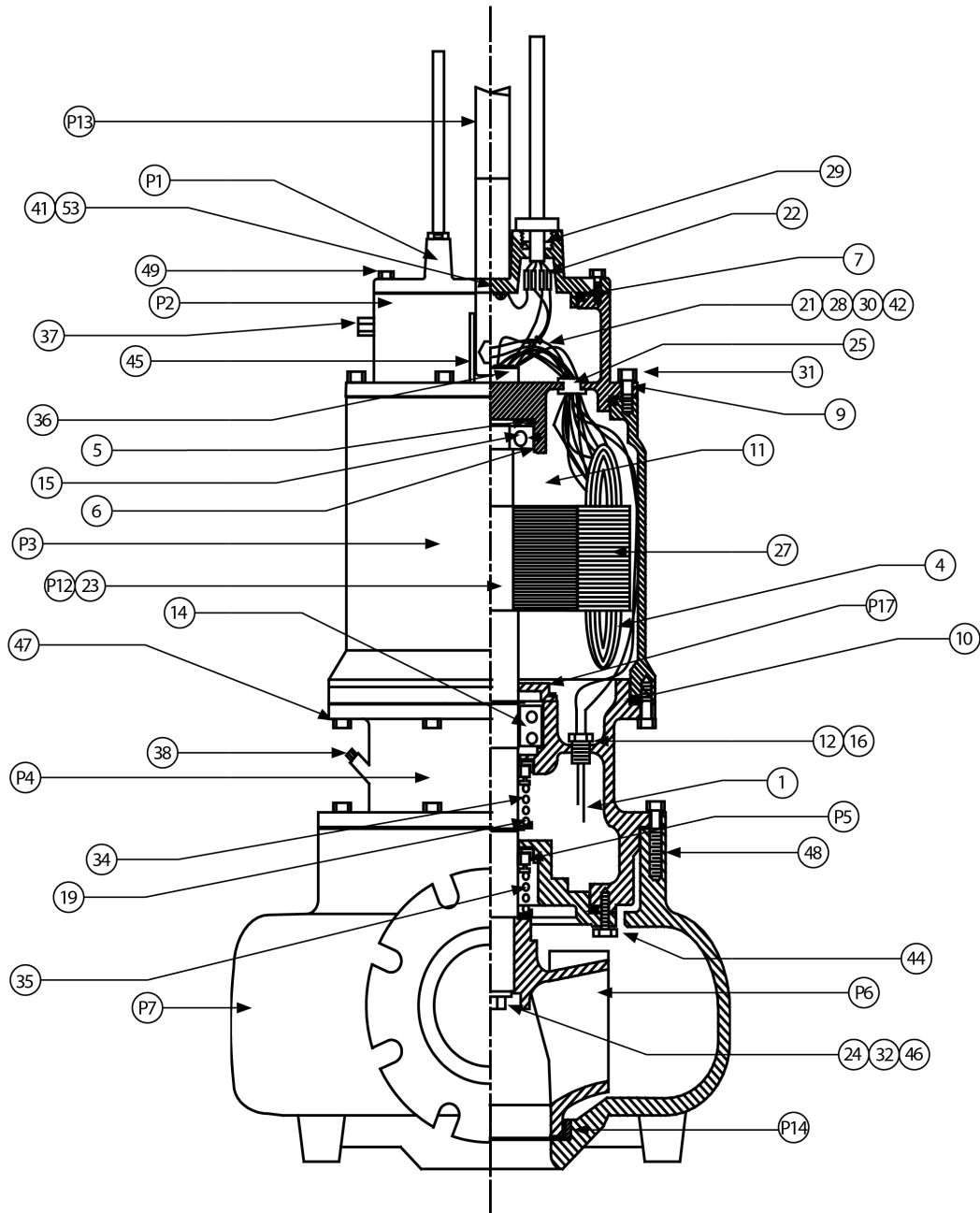

6ANC1000M3-35 & 6ANC1500M3-35 6ANC2000M3-35					
MODEL No.	QTY.	PART No.	QTY.	PART No.	DESCRIPTION
P1	1	3DTFL10004	1	3DTFL20005	CORD CAP 35'
P2	1	3TAFL10001	1	3TAFL20002	INTERMEDIATE CORD CAP
P3	1	3CMFL10GP0	1	3CMFL15GP0	MOTOR HOUSING
P4	1	3CAFL10005	1	3CAFL20153	BEARING HOUSING
P5	1	3TCFL10007	1	3TCFL10007	SEAL PLATE
P6	1	3IMFL10157	1	3IMFL15516	IMPELLER
	1	3IMFL10157	1	3IMFL20158	
	1	3IMFL15516	1		
P7	1	3CCFL100G0	1	3CCFL200G2	VOLUTE CASE



Solids Handling Pumps

Models: 6ANC1000M3-35, 6ANC1500M3-35 and 6ANC2000M4-35

6ANC1000M3-35 & 6ANC1500M3-35 6ANC2000M3-35					
MODEL No.	QTY.	PART No.	QTY.	PART No.	DESCRIPTION
P12	1	3FR0L101W1	1	3FR0L105D1	SHAFT W/ROTOR
	1	3FR0L101D1	1	3FR0L102W1	
	1	3FR0L101W1			
P13	1	3MA43M1759	1	3MA4022078	HANDLE
P14	1	3ADB404603	1	3ADB404603	WEAR RING
P15	1	3SP1L100G8	1	3SP1L100G8	SUPPORT (PORTABLE EQUIPMENT)
P16	1	3SSF024003	1	3SSF024003	UPPER SUPPORT
P17	-	-	-	-	BEARING COVER
1	3.5	1ACL38KVD5	5	1ACLSAE101	OIL (L)
4	2	1ALC0022N8	2	1ALC0022N8	MOISTURE SENSOR WIRE
5	1	1ORN023372	1	1ORN023778	-RING
6	1	1ORN033374	1	1ORN033770	O-RING
7	1	1ORN035979	1	1ORN036373	O-RING
8	1	1ORN036373	1	1ORN036373	O-RING
9	1	1ORN036870	1	1ORN037376	O-RING
1	9	1ACL38KVD5	12	1ACL38KVD5	OIL (L)
12	2	1TDE558501	2	1TDE558501	ELECTRICAL TERMINAL
13	1	1EMNL15005	1	1EMNL15005	GASKET
14	1	1BA7320905	1	1BA7320921	LOWER BEARING
	1	1BA7320921	1	1BA7320905	
	1	1BA7320905	-	-	
15	1	1BA7630601	-	1BA7630601	UPPER BEARING
	1	1BA7620920	-	-	
	1	1BA7630627	1	1BA7620904	
16	2	3BU0030203	2	3BU0030203	MOISTURE SENSOR
18	-	-	-	-	SNAP RING
19	1	1CT9141759	1	1CT9141759	SNAP RING
20	7	1CNN190009	7	1CNN190009	NYLON BELT
21	4	1COCA416A1	4	1COCA416A1	THREADED CONNECTOR
23	1	3CU8021208	1	3CU8039844	KEY
24	1	3CU4031772	1	3CU4031772	KEY
25	2	1EPN000176	2	1EPN000176	WIRE-PASS PACKING
26	1	1EPN0006P9	1	1EPN0006P9	GASKET
27	1	1ESE100404	1	1ESE150405	STATOR
31	4	1TO45M08E8	4	1TO40308E4	HEX HEAD CAP SCREW
32	2	1RO40615P0	2	1RO40615P0	IMPELLER WASHER
34	1	1SEE140010	1	1SEE140010	UPPER SEAL
35	1	1SEE140010	1	1SEE140010	LOWER SEAL
36	1	1TA0060604	1	1TA0060604	CONNECTION BLOCK
37	1	1TMB01NP09	1	1TMB01NP09	PIPE PLUG
38	3	1TMB02NP00	3	1TMB02NP00	PIPE PLUG
41	1	1TO83M02G5	1	1TO83M02G5	FILLISTER HEAD SCREW
42	2	1TO83M06G1	2	1TO83M06G1	FILLISTER HEAD SCREW
44	6	1TO40206E9	6	1TO40206E9	HEX HEAD CAP SCREW
45	2	1TO40408E5	2	1TO40408E5	HEX HEAD CAP SCREW
46	1	1TO40610E9	1	1TO40610E9	HEX HEAD CAP SCREW
47	8	1TO45M08E8	8	1TO40310E5	HEX HEAD CAP SCREW
48	8	1TO45M08E8	8	1TO45M08E8	HEX HEAD CAP SCREW
49	4	1TO45M08E8	4	1TO45M08E8	HEX HEAD CAP SCREW
50	-	-	-	-	HEX HEAD CAP SCREW
51	4	1TO40414E2	4	1TO40414E2	HEX HEAD CAP SCREW
53	1	1ZAC3M08J6	1	1ZAC3M0605	BUTTED SEAM TERMINAL



Solids Handling Pumps Models: 6ANC3000M4-35 Repair Parts

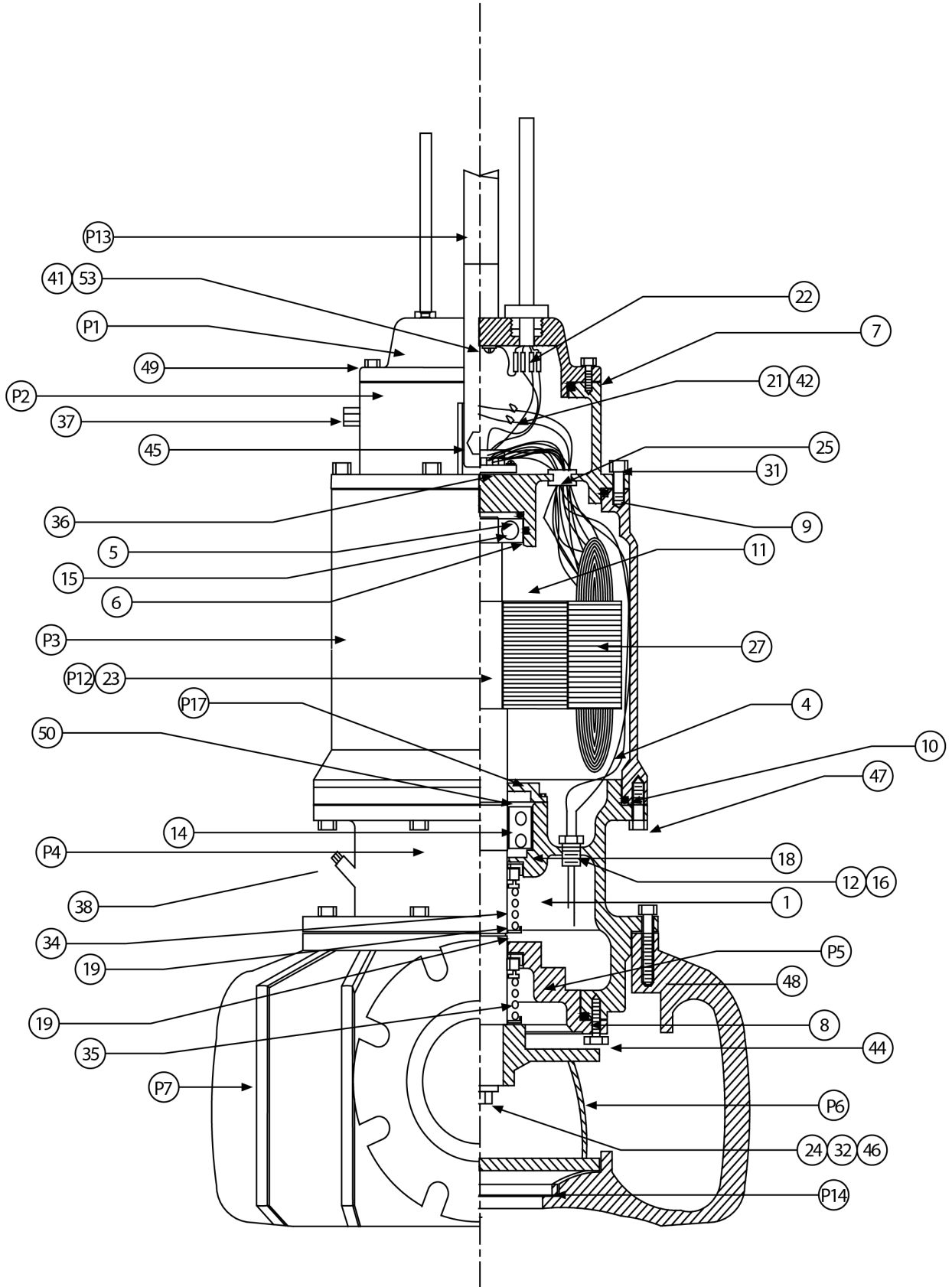



Solids Handling Pumps

Models: 6ANC3000M4-35

Repair Parts List

MODEL#	QTY.	PART No.	DESCRIPTION
P1	1	3DFL20005	CORD CAD 35'
P2	1	3TAF20002	INTERMEDIATE CORD CAP
P3	1	3CMFL20GP0	MOTOR HOUSING
P4	1	3CAFL30201	BEARING HOUSING
P5	1	3TCFL10007	SEAL PLATE
P6	1	3IMFL20158	IMPELLER
		3IMFL32450	
P7	1	3CCFL200G2	VOLUTE CASE
P12	1	3FR0L102D1	SHAFT W/ROTOR
P13	1	3MA4022078	HANDLE
P14	1	3ADB404603	WEAR RING SUPPORT
P17	1	3TBFL30200	BEARING COVER
1	6	1ACLSAE101	OIL (L)
		1ACL38KVD5	
4	2	1ALC0022N8	MOISTURE SENSOR WIRE
5	1	1ORN023778	O-RING
6	1	1ORN033770	O-RING
7	1	1ORN036373	O-RING
8	1	1ORN036373	O-RING
9	1	1ORN037376	O-RING
10	1	1ORN037873	O-RNG
11	9	1ACL38KVD5	OIL (L)
12	2	1TDE558501	NAKED FEMALE ELECTRICAL TERMINAL
13	1	1EMNL15005	GASKET
14	1	1BA7330923	LOWER BEARING
		1BA7330907	
15	1	1BA7620920	UPPER BEARING
		1BA7620904	
16	2	3BU0030203	MOISTURE SENSOR
18	1	1CT9141775	SNAP RING
19	1	1CT9141759	SNAP RING

MODEL#	QTY.	PART No.	DESCRIPTION
21	4	1COCA416A1	THREADED CONNECTOR
23	1	3CU8039844	KEY
24	1	3CU4031772	KEY
25	1	1EPN000176	WIRE-PASS PACKING
27	1	1ESE200404	STATOR
31	4	1TO40308E4	HEX HEAD CAP SCREW
32	1	1RO40615P0 F	LAT WASHER
33	8	1RO40600P2	FLAT WASHER
34	1	1SEE140010	UPPER SEAL
35	1	1SEE140010	LOWER SEAL
36	1	1TA0060604	CONNECTION BLOCK
			220V
37	1	1TMB01NP09	MALE PLUG
38	3	1TMB02NP00	MALE PLUG
41	1	1TO83M02G5	FILLISTER HEAD SCREW
42	2	1TO83M06G1	FILLISTER HEAD SCREW
43	-	-	ALLEN SCREW
44	6	1TO40206E9	HEX HEAD CAP SCREW
45	2	1TO40408E5	HEX HEAD CAP SCREW
46	1	1TO40610E9	HEX HEAD CAP SCREW
47	8	1TO40310E5	HEX HEAD CAP SCREW
48	8	1TO40308E4	HEX HEAD CAP SCREW
49	4	1TO45M08E8	HEX HEAD CAP SCREW
50	4	1TO45M08E8	HEX HEAD CAP SCREW
53	1	1ZAC3M0605	BUTTED SEAM TERMINAL



Solids Handling Pumps

Models: 6ANC4000M4-35, 6ANC5000M4-35 and 6ANC6000M4-35 Repair Parts

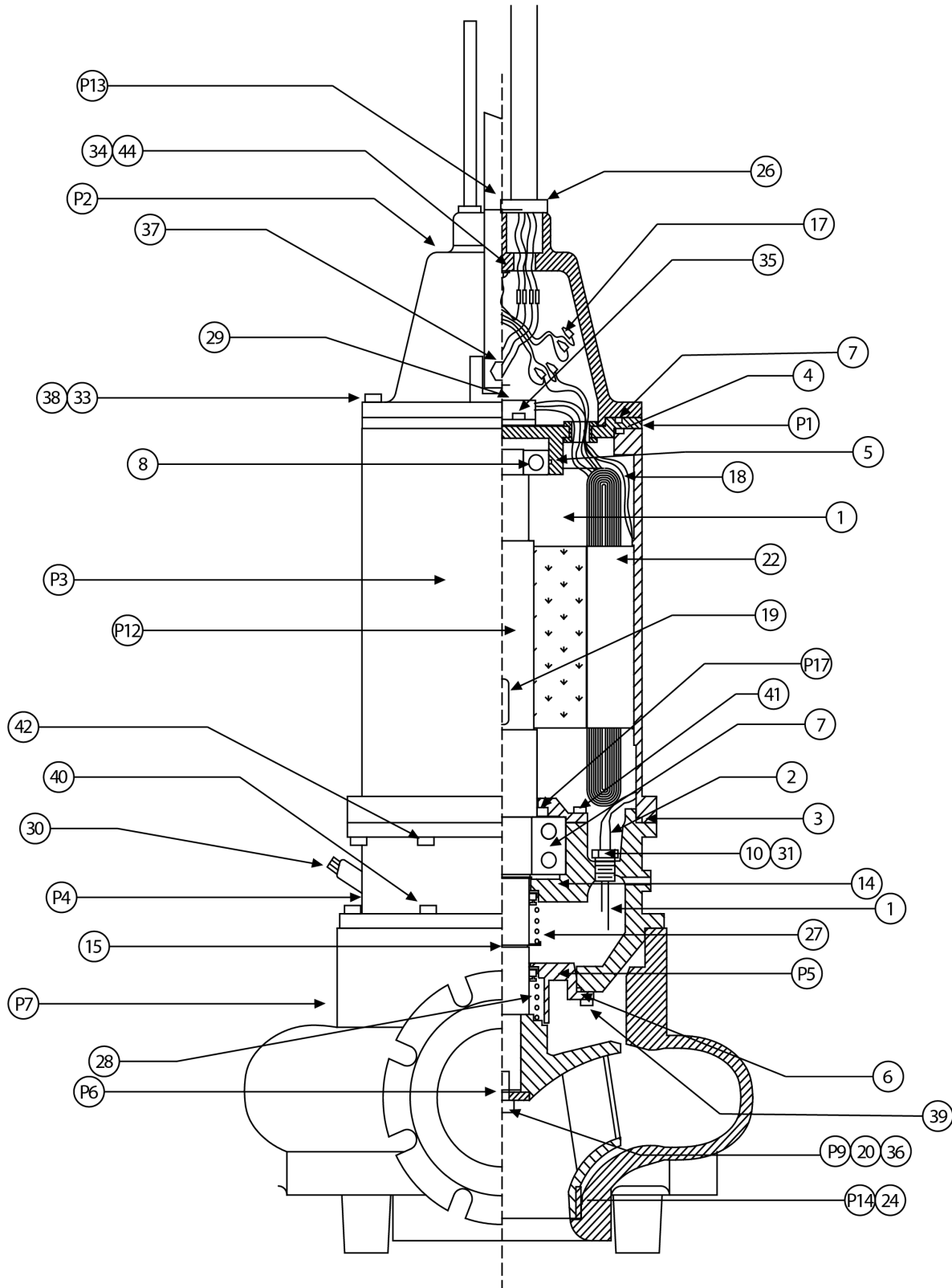



Solids Handling Pumps

Models: 6ANC4000M4-35, 6ANC5000M4-35 and 6ANC6000M4-35 Repair Parts List

6ANC4000M4-35 & 6ANC5000M4-35 & 6ANC6000M4-35							
MODELS	QTY.	PART No.	QTY.	PART No.	QTY.	PART No.	DESCRIPTION
P1	1	3TMFL40001	1	3TMFL40001	1	3TMFL40001	UPPER BEARING PLATE
P2	1	3TAFL40240	1	3TAFL40240	1	3TAFL40240	CORD CAP 35'
P3	2	1 3CMFL40209	1	3CMFL206W0	1	3CMFL206W0	MOTOR HOUSING
P4	1	3CAFL40000	1	3CAFL206W0	1	3CAFL206W0	BEARING HOUSING
P5	1	3TCFL40001	1	3TCFL40001	1	3TCFL40001	SEAL PLATE
P6	1	3IMFL40415	1	3IMFL150415	1	3IMFL60415	IMPELLER
P7	1	3CCFL15150	1	3CCFL15150	1	3CCFL15150	VOLUTE CASE
P9	1	3RO4L30006	1	3RO4L30006	1	3RO4L30006	IMPELLER WASHER
P12	1	3FR0L40415	1	3FR0L206W0	1	3FR0L206W0	SHAFT W/ROTOR
P13	1	3MA4022693	1	3MA4022693	1	3MA4022693	HANDLE
P14	1	3AD6058501	1	3AD6058501	1	3AD6058501	WEAR RING
P17	1	3TBFL40008	1	3TBFL40008	1	3TBFL40008	BEARING COVER
1	25.5	1ACL38KVD5	19.5	1ACL38KVD5	1.95	1ACL38KVD5	OIL (1)
2	1.8	1ALC0022N8	1.8	1ALC0022N8	1.8	1ALC0022N8	MOISTURE SENSOR WIRE
3	1	1ORN045371	1	1ORN045371	1	1ORN045371	O-RING
4	1	1ORN044977	1	1ORN044977	1	1ORN044977	O-RING
5	1	1ORN024578	1	1ORN024578	1	1ORN024578	O-RING
6	1	1ORN036474	1	1ORN036474	1	1ORN036474	O-RING
7	1	1ORN045077	1	1ORN045077	1	1ORN044977	O-RING
8	1	1BA7631005	1	1BA7631005	1	1BA7631005	UPPER BEARING
9	1	1BA7331402	1	1BA7331402	1	1BA7331402	LOWER BEARING
10	2	3BU0030203	2	3BU0030203	2	3BU0030203	MOISTURE SENSOR
14	1	1CT9512759	1	1CT9512759	1	1CT9512759	SNAP RING
15	1	1CT9142504	1	1CT9142504	1	1CT9142504	SNAP RING
17	4	1COE2214R0	4	1COE2214R0	4	1COE2214R0	THREAD CONNECTOR
18	6	1COC0016Z9	6	1COC0016Z9	6	1COC0016Z9	BUTT CONNECTOR
19	1	3CU8032552	1	3CU8051961	1	3CU8051961	KEY
20	1	3CU4031696	1	3CU4031696	1	3CU4031696	KEY
21	1	1EPN000176	1	1EPN000176	1	1EPN000176	WIRE PASS THROUGH GASKET
22	1	1ESE400404	1	1ESE400404	1	1ESE400404	STATOR
24	2	1PR40204L0	2	1PR40204L0	2	1PR40204L0	SET SCREW
27	1	1SEE200017	1	1SEE200017	1	1SEE200017	UPPER SEAL
28	1	1SEE200017	1	1SEE200017	1	1SEE200017	LOWER SEAL
29	1	1TA0030305	1	1TA0060604	1	1TA0060604	CONNECTION BLOCK
30	6	1TMB02NP00	6	1TMB02NP00	6	1TMB02NP00	PIPE PLUG
31	2	1TDE558501	2	1TDE558501	2	1TDE558501	FEMALE TERMINAL
34	1	1TO80204G8	1	1TO80204G8	1	1TO80204G8	FILLISTER HEAD SCREW
35	2	1TO83M06G1	2	1TO83M06G1	2	1TO83M06G1	FILLISTER HEAD SCREW
36	1	1TO40712E4	1	1TO40712E4	1	1TO40712E4	HEX HEAD CAP SCREW
37	2	1TO40510E8	2	1TO40510E8	2	1TO40510E8	HEX HEAD CAP SCREW
38	8	1TO40312E8	8	1TO40312E8	8	1TO40312E8	HEX HEAD CAP SCREW
39	6	1TO40206E9	6	1TO40206E9	6	1TO40206E9	HEX HEAD CAP SCREW
40	8	1TO40310E5	8	1TO40310E5	8	1TO40310E5	HEX HEAD CAP SCREW
41	4	1TO40304E4	4	1TO40304E4	4	1TO40304E4	HEX HEAD CAP SCREW
42	8	1TO40312E8	8	1TO40312E8	8	1TO40312E8	HEX HEAD CAP SCREW
43	0.2	1TCC020004	0.2	1TCC020004	0.2	1TCC020004	FLEXIBLE PIPING (m)
44	1	1ZAC3M0605	2	1ZAC3M0605	2	1ZAC3M0605	EYELET TERMINAL
45	1	1EPN0006P9	1	1EPN0006P9	1	1EPN0006P9	GASKET
46	1	1EMNL15005	1	1EMNL15005	1	1EMNL15005	GASKET
47	8	1RO40600P2	8	1RO40600P2	8	1RO40600P2	FLAT WASHER
48	4	1TO40414E2	4	1TO40414E2	4	1TO40414E2	HEX HEAD CAP SCREW
49	8	1TO40616E8	8	1TO40616E8	8	1TO40616E8	HEX HEAD CAP SCREW



Solids Handling Pumps Models: 8ANC5000M4-35 and 8ANC6000M4-35 Repair Parts

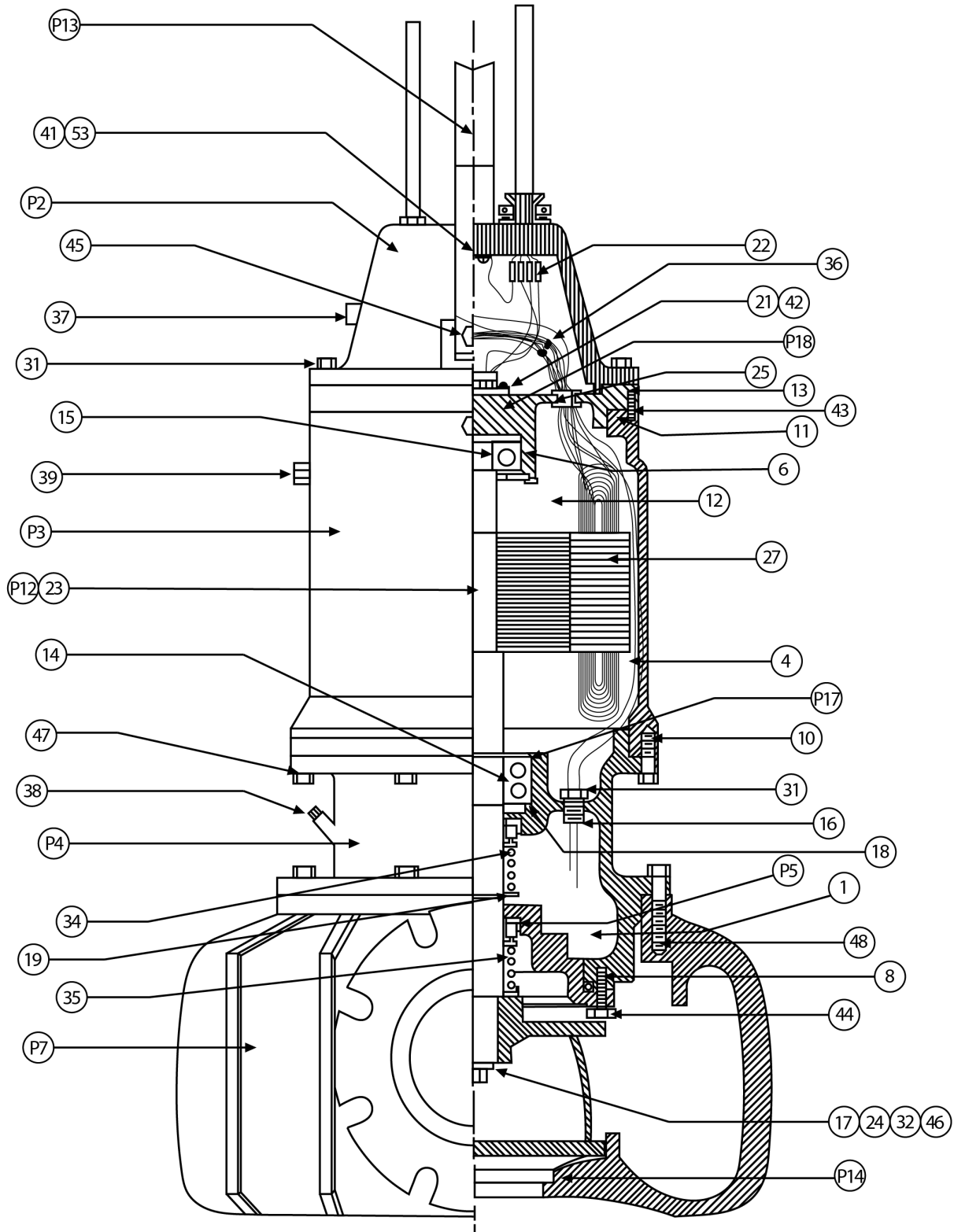



Solids Handling Pumps

Models: 8ANC5000M4-35 and 8ANC6000M4-35 Repair Parts Lists

MODEL	QTY.	PART No.	DESCRIPTION
P2	1	3TAFL40224	CORD CAP 35'
P3	1	3CMFL206W0	MOTOR HOUSING
P4	1	3CAFL206W0	BEARING HOUSING
P5	1	3TCFL40001	SEAL PLATE
P6	1	3IMFL50283	IMPELLER
	1	3IMFL60008	
P7	1	3CCFL400G5	VOLUTE CASE
P12	1	3FR0L206W0	SHAFT W/ROTOR
P13	1	3MA4022693	HANDLE
P14	1	3ADBL20300	WEAR RING
P17	1	3TBFL40008	BEARING COVER
P18	1	3TMFL40001	UPPER BEARING PLATE
1	-	1ACL38KVD5	OIL (L)
4	2	1ALC0022N8	MOISTURE SENSOR WIRE
5	-	-	O-RING
6	1	1ORN024578	O-RING
7	-	-	O-RING
8	1	1ORN036474	O-RING
9	-	-	O-RING
10	1	1ORN045371	O-RING
11	1 1	ORN044977	O-RING
1	15	1ACL38KVD5	OIL (L)
13	1	1ORN045077	O-RING
14	1	1BA7331402	LOWER BEARING
15	1	1BA7631005	UPPER BEARING
16	2	3BU0030203	MOISTURE SENSOR
17	2	1PR40204L0	KEY
18	1	1CT9512759	SNAP RING
19	1	1CT9142504	SNAP RING
21	4	1COCA416A1	THREADED CONNECTOR
22	6	1COC0016Z9	CONNECTOR CAP
23	1	3CU8051961	KEY
24	1	3CU4031696	KEY
25	1	1EPN000176	WIRE-PASS PACKING
26	1	1EPN0008P2	GASKET
27	1	1ESE400404	STATOR
31	2	1TDE558501	NAKED FEMALE ELECTRIC TERMINAL
32	1	-	IMPELLER WASHER
34	1	1SEE200017	UPPER SEAL

MODEL35	QTY.	PART No.	DESCRIPTION
35			LOWER SEAL
36	1	9BD1643226	CONNECTION BLOCK
37	1	1TMB02NP00	PIPE PLUG
38	3	1TMB02NP00	PIPE PLUG
39	1	1TMB02NP00	PIPE PLUG
41	1	1TO83M04G8	FILLISTER HEAD SCREW
42	2	1TO83M06G1	FILLISTER HEAD SCREW
43	2	1TO40206L0	ALLEN SCREW
44	6	1TO40206E9	HEX HEAD CAP SCREW
45	2	1TO40510E8	HEX HEAD CAP SCREW
46	1	1TO40712E4	HEX HEAD CAP SCREW
47	8	1TO40312E8	HEX HEAD CAP SCREW
48	8	1TO40310E5	HEX HEAD CAP SCREW
49	-	-	HEX HEAD CAP SCREW
50	4	1TO40208E2	HEX HEAD CAP SCREW
51	8	1TO40620E2	HEX HEAD CAP SCREW
52	4	1TO40414E2	HEX HEAD CAP SCREW
53	2	1ZAC3M0605	BUTTED SEAM TERMINAL



Solids Handling Pumps Oil Fill and Wiring Charts

Pump Model	HP	Seal Housing Oil Level (Qt.)	Motor Housing Oil Level (Qt.)
3ANC300M3	3	1.69	4.76
3ANC300M4	3	1.69	4.76
3ANC500M3	5	3.7	5.28
3ANC500M4	5	3.7	5.28
3ANC750M3	7.5	3.7	5.28
3ANC750M4	7.5	3.7	5.25
4ANC2500M4	25	10.57	31.91
4ANC3000M4	30	10.57	31.91
4ANC4000M4	40	10.57	31.91
4ANC5000M4	50	10.57	66.57
4ANC6000M4	60	10.57	66.57
6ANC1000M3	10	9.51	24.3
6ANC1000M4	10	9.51	24.3
6ANC1500M3	15	9.51	24.3
6ANC1500M4	15	9.51	24.3
6ANC2000M4	20	10.57	24.3
6ANC3000M4	30	10.57	31.91
6ANC4000M4	40	10.57	31.91
6ANC5000M4	50	10.57	66.57
6ANC6000M4	60	10.57	66.57
8ANC5000M4	50	10.57	66.57
8ANC6000M4	60	10.57	66.57

Wiring Diagram (Dual/Single Voltage)

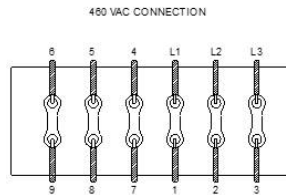
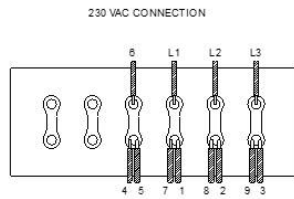

40 HP, 50 HP, 60 HP

480 VAC CONNECTION

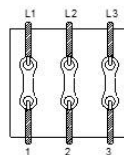



Solids Handling Pumps
Models: 3ANC300/500/750,
4ANC2500/3000/4000/5000/6000
6ANC1000/1500/2000/3000/4000/5000/6000
8ANC5000/6000 Warranty

For a period of time no greater than one (1) year after the original purchase of the subject product, and subject to the conditions of this Limited Warranty, Ashland Pump will repair or replace for the original purchaser only, any portion of your new Ashland Pump product that proves to contain defective materials or defective workmanship, provided the product is properly installed, serviced and operated under normal conditions and according to the manufacturer's instructions.

Ashland Pump disclaims all liability, including liability under this Limited Warranty, for improper installation, application or use of its products. Ashland Pump shall have and possess the sole discretion to determine whether to repair or replace defective equipment, parts or components with a new or remanufactured part. Any item to be replaced under this Warranty must be returned to Ashland Pump, or such other place as Ashland Pump may designate, freight prepaid. In the absence of suitable proof of purchase date, the effective date of this warranty will be based upon the date of manufacture as evidenced by the serial number of the product.

There is no other express or implied warranty covering your Ashland Pump product. Without limiting the foregoing, Ashland Pump specifically disclaims the implied warranties of merchantability and fitness for a particular purpose. No warranties or representations at any time made by any representative of Ashland Pump shall vary or expand the provisions of this written Limited Warranty. This Limited Warranty contains the purchaser's exclusive remedy for any alleged defect in the product.

To the greatest extent permissible by applicable law, Ashland Pump shall not be liable or responsible for consequential, incidental or special damages resulting from or related in any manner to any Ashland Pump product or parts. Personal injury and/or property damage may result from improper installation, application or use of your Ashland Pump product. Ashland Pump shall not be liable for any loss, damage, or expenses resulting from the installation or use of its products other than as expressly set forth in this Limited Warranty. Ashland Pump shall in no event be responsible or liable for the cost of field labor or other charges incurred by any purchaser or user in removing and/or reaffixing any Ashland Pump product, part or component or any temporary pumping or other equipment. Some states do not allow the exclusion or limitation of incidental or consequential damages, so the above limitation or exclusion may not apply to you.



Honest, Professional, Dependable

1899 Cottage Street, Ashland, Ohio 44805
Telephone: 855 281-6830 • Fax: 877 326-1994
ashlandpump.com